

# IGBTs

## Selection guide



September 2009

## Low drop IGBTs (switching frequency up to 1 kHz)

Part number	Voltage $V_{CES}$ (V)	Package	Current $I_C$ at $T_C = 100\text{ }^\circ\text{C}$ (A)	On voltage at $T_C = 125\text{ }^\circ\text{C}$ , $V_{GE} = 15\text{ V}$		Anti-parallel diode	
				$V_{CE(sat)}$ (V)	$I_C$ (A)		
STGD3NB60SDT4	600	DPAK	3	1.1	3	Y	
STGD7NB60ST4			7	1.1	7		
STGD3NB60SD-1		IPAK	3	1.1	3	Y	
STGB3NB60SDT4		D <sup>2</sup> PAK	3	1.1	3	Y	
STGB10NB60ST4			10	1.25	10		
STGF7NB60SL		TO-220FP	7	1.1 <sup>1</sup>	7		
STGP10NB60SFP			7	1.25	10		
STGF10NB60SD			7	1.25	10	Y	
STGF20NB60S			13	1.2	20		
STGP10NB60S		TO-220	10	1.25	10		
STGP10NB60SD			10	1.25	10	Y	
STGW35NB60SD		TO-247	35	1.2	20	Y	
STGE200NB60S		ISOTOP	150	1.2	150		
STGD5NB120SZT4		1200	DPAK	5	1.2	5	
STGD5NB120SZ-1			IPAK	5	1.2	5	
STGD7NB120S-1	7			1.7	10		

1.  $V_{GE} = 4.5\text{ V}$

## Fast IGBTs (switching frequency up to 10 kHz)

Part number	Voltage $V_{CES}$ (V)	Package	Current $I_C$ at $T_C = 100\text{ }^\circ\text{C}$ (A)	On voltage at $T_C = 125\text{ }^\circ\text{C}$ , $V_{GE} = 15\text{ V}$		Anti-parallel diode
				$V_{CE(sat)}$ (V)	$I_C$ (A)	
STGP100N30	600	TO-220	45	2.6	100	
STGD10NC60ST4		DPAK	10	1.3	5	
STGD10NC60SDT4			10	1.3	5	Y
STGF10NC60SD		TO-220FP	5	1.3	5	Y
STGF30NC60S			11	1.4	20	
STGB19NC60ST4		D <sup>2</sup> PAK	20	1.35	12	
STGP10NC60S		TO-220	11	1.3	5	
STGP19NC60S			20	1.35	12	
STGP19NC60SD			20	1.35	12	Y
STGP30NC60S			35	1.4	20	

## Very fast IGBTs (switching frequency up to 50 kHz)

Part number	Voltage $V_{CES}$ (V)	Package	Current $I_C$ at $T_C = 100\text{ }^\circ\text{C}$ (A)	On voltage at $T_C = 125\text{ }^\circ\text{C}$ , $V_{GE} = 15\text{ V}$		Anti-parallel diode	
				$V_{CE(sat)}$ (V)	$I_C$ (A)		
STGD6NC60HDT4	600	DPAK	7	1.7	3	Y	
STGD10NC60HDT4			10	1.7	5	Y	
STGD10NC60HT4			10	1.7	5		
STGD7NC60HT4			14	1.7	7		
STGB6NC60HDT4		D <sup>2</sup> PAK	7	1.7	3	Y	
STGB10NC60HDT4			10	1.7	5	Y	
STGB7NC60HDT4			14	1.7	7	Y	
STGB19NC60HDT4			19	1.6	12	Y	
STGB20NC60VT4		30	1.7	20			
STGF6NC60HD		TO-220FP	3	1.7	3	Y	
STGF10NC60HD			6	1.7	5	Y	
STGF7NC60HD			8	1.7	7	Y	
STGF19NC60HD			10	1.6	12	Y	
STGP6NC60HD		TO-220	7	1.7	3	Y	
STGP10NC60H			10	1.7	5		
STGP10NC60HD			10	1.7	5	Y	
STGP7NC60H			14	1.7	7		
STGP7NC60HD			14	1.7	7	Y	
STGP19NC60H			19	1.6	12		
STGP19NC60HD			19	1.6	12	Y	
STGP20NC60V			30	1.7	20		
STGW19NC60HD		TO-247	21	1.6	12	Y	
STGW20NC60V			30	1.7	20		
STGW20NC60VD			30	1.7	20	Y	
STGW30NC60VD <sup>2</sup>			40	1.7	20	Y	
STGW39NC60VD			40	1.7	30	Y	
STGW45NC60VD <sup>2</sup>			50	1.7	30	Y	
STGW40NC60V			50	1.7	40		
STGY40NC60VD			Max247	50	1.7	40	Y
STGE50NC60VD		ISOTOP	50	1.7	40	Y	
STGW30N90D		900	TO-247	30	2	20	Y
STGF3NC120HD		1200	TO-220FP	3	2.2	3	Y
STGW30NC120HD	TO-247		30	2	20	Y	
STGW35NC120HD <sup>2</sup>			34	2	20	Y	
STGWS38IH130D			25	2	20	Y	
STGW38IH130D <sup>2</sup>			33	2	20	Y	
	1300						

2. TO-247 long leads

## Short-circuit rugged IGBTs (switching frequency up to 50 kHz)

Advanced planar PT technology (new generation)							
Part number	Voltage $V_{CES}$ (V)	Package	Current $I_C$ at $T_C = 100\text{ }^\circ\text{C}$ (A)	On voltage at $T_C = 150\text{ }^\circ\text{C}$ , $V_{GE} = 15\text{ V}$		Anti-parallel diode	
				$V_{CE(sat)}$ (V)	$I_C$ (A)		
STGF10HF60KD <sup>3</sup>	600	TO-220FP	6	1.6	5	Y	
STGF14HF60KD <sup>3</sup>			7	1.8	7	Y	
STGD10HF60KDT4 <sup>3</sup>		DPAK	10	1.6	5	Y	
STGB10HF60KDT4 <sup>3</sup>		D <sup>2</sup> PAK	10	1.6	5	Y	
STGP10HF60KD <sup>3</sup>		TO-220	10	1.6	5	Y	
STGP14HF60KD <sup>3</sup>			14	1.8	7	Y	
Planar PT technology							
Part number	Voltage $V_{CES}$ (V)	Package	Current $I_C$ at $T_C = 100\text{ }^\circ\text{C}$ (A)	On voltage at $T_C = 125\text{ }^\circ\text{C}$ , $V_{GE} = 15\text{ V}$		Anti-parallel diode	
				$V_{CE(sat)}$ (V)	$I_C$ (A)		
STGD8NC60KT4	600	DPAK	8	1.8	3		
STGD8NC60KDT4			8	1.8	3	Y	
STGD10NC60KT4			10	1.8	5		
STGD10NC60KDT4			10	1.8	5	Y	
STGD14NC60KT4			14	1.8	7		
STGB8NC60KT4		D <sup>2</sup> PAK	8	1.8	3		
STGB8NC60KDT4			8	1.8	3	Y	
STGB10NC60KT4			10	1.8	5		
STGB10NC60KDT4			10	1.8	5	Y	
STGB14NC60KT4			14	1.8	7		
STGB14NC60KDT4			14	1.8	7	Y	
STGB19NC60KDT4			20	1.8	12	Y	
STGB30NC60KT4			26	1.9	20		
STGF8NC60KD			TO-220FP	4	1.8	3	Y
STGF10NC60KD				6	1.8	5	Y
STGF14NC60KD		7		1.8	7	Y	
STGF19NC60KD		10		1.8	12	Y	
STGP8NC60K		TO-220		8	1.8	3	
STGP8NC60KD			8	1.8	3	Y	
STGP10NC60K			10	1.8	5		
STGP10NC60KD			10	1.8	5	Y	
STGP14NC60KD			14	1.8	7	Y	
STGP19NC60KD			20	1.8	12	Y	
STGP30NC60K			26	1.9	20		
STGW30NC60KD			TO-247	28	1.9	20	Y
STGW40NC60KD				38	1.9	30	Y
STGW30N120KD			1200	TO-247	30	2.7	20
STGW40N120KD		40			2.7	30	Y

3. Samples available from Q4 2009

# Ultra and hyper fast IGBTs (switching frequency up to 100 kHz)

## Advanced planar PT technology (new generation)

Part number	Voltage $V_{CES}$ (V)	Package	Current $I_C$ at $T_C = 100\text{ °C}$ (A)	On voltage at $T_C = 125\text{ °C}, V_{GE} = 15\text{ V}$		Anti-parallel diode
				$V_{CE(sat)}$ (V)	$I_C$ (A)	
STGW35HF60WD	600	TO-247	35	1.65	20	Y
STGW35HF60WDI			35	1.65	20	Y
STGWA35HF60WDI <sup>2</sup>			40	1.65	20	Y
STGW45HF60WD			45	1.7	30	Y
STGW45HF60WDI			45	1.7	30	Y
STGWA45HF60WDI <sup>2</sup>			50	1.7	30	Y

## Planar PT technology

Part number	Voltage $V_{CES}$ (V)	Package	Current $I_C$ at $T_C = 100\text{ °C}$ (A)	On voltage at $T_C = 125\text{ °C}, V_{GE} = 15\text{ V}$		Anti-parallel diode		
				$V_{CE(sat)}$ (V)	$I_C$ (A)			
STGDL6NC60DT4	600	DPAK	5	2	3	Y		
STGDL6NC60DIT4			5	2	3	Y		
STGBL6NC60DT4		D <sup>2</sup> PAK	6	2	3	Y		
STGBL6NC60DIT4			6	2	3	Y		
STGB19NC60WT4		TO-220FP	22	1.8	12			
STGFL6NC60D			3	2	3	Y		
STGFL6NC60DI			3	2	3	Y		
STGF19NC60WD		TO-247	7	1.8	12	Y		
STGPL6NC60D			TO-220	6	2	3	Y	
STGPL6NC60DI				6	2	3	Y	
STGP19NC60W			TO-247	22	1.8	12		
STGP19NC60WD				22	1.8	12	Y	
STGW19NC60W				23	1.8	12		
STGW19NC60WD				23	1.8	12	Y	
STGW40NC60W				TO-247	40	1.9	30	
STGW40NC60WD					40	1.9	30	Y
STGW45NC60WD <sup>2</sup>				45	1.9	30	Y	
STGW50NC60W				50	1.9	40		
STGY50NC60WD				Max247	50	1.9	40	Y
STGE50NC60WD				ISOTOP	50	1.9	40	Y

2. TO-247 long leads

## Internally clamped IGBTs for electronic ignition

Part number	Clamped voltage $V_{CES}$ (V)	Package	Current $I_C$ at $T_C = 100\text{ }^\circ\text{C}$ (A)	On voltage at $T_C = 125\text{ }^\circ\text{C}$ , $V_{GE} = 4.5\text{ V}$	
				$V_{CE(sat)}$ (V)	$I_C$ (A)
STGB35N35LZT4	350	D <sup>2</sup> PAK	30	1.35	15
STGB35N35LZ-1		I <sup>2</sup> PAK	30	1.35	15
STGD18N40LZT4	390	DPAK	25	1.3	10
STGD18N40LZ-1		IPAK	25	1.3	10
STGB18N40LZT4		D <sup>2</sup> PAK	30	1.3	10
STGB18N40LZ-1		I <sup>2</sup> PAK	30	1.3	10
STGP18N40LZ		TO-220	30	1.3	10
STGB20NB37LZT4		400	D <sup>2</sup> PAK	20	1.3
STGB10NB37LZT4	410	D <sup>2</sup> PAK	10	1.3	20
STGB10NB40LZT4			10	1.3	20
STGB20NB41LZT4			20	1.3	20
STGP10NB37LZ		TO-220	10	1.3	20

## IGBT intelligent power modules (IPM)

Part number	Voltage $V_{CES}$ (V)	Package	Current $I_C$ at $T_C = 25\text{ }^\circ\text{C}$ (A)	On voltage at $T_C = 125\text{ }^\circ\text{C}$ , $V_{GE} = 15\text{ V}$	
				$V_{CE(sat)}$ (V)	$I_C$ (A)
STGIPS10K60A	600	SDIP-25L Molded	10	1.8	5
STGIPS14K60			12	1.8	7
STGIPS20K60			17	1.8	12
STGIPL14K60		SDIP-38L Molded	14	1.8	7
STGIP3M25N60		SEMITOP 3	25 <sup>4</sup>		20

4.  $T_C = 80\text{ }^\circ\text{C}$

## IGBT power modules for 3-phase inverters

Part number	Voltage $V_{CES}$ (V)	Package	Current $I_C$ at $T_C = 80\text{ }^\circ\text{C}$ (A)	On voltage at $T_C = 125\text{ }^\circ\text{C}$ , $V_{GE} = 15\text{ V}$		Power dissipation (W)
				$V_{CE(sat)}$ (V)	$I_C$ (A)	
STG3P2M10N60B	600	SEMITOP 2	10	1.7	7	56
STG3P3M25N60		SEMITOP 3	25	1.7	20	96

## IGBT ordering information

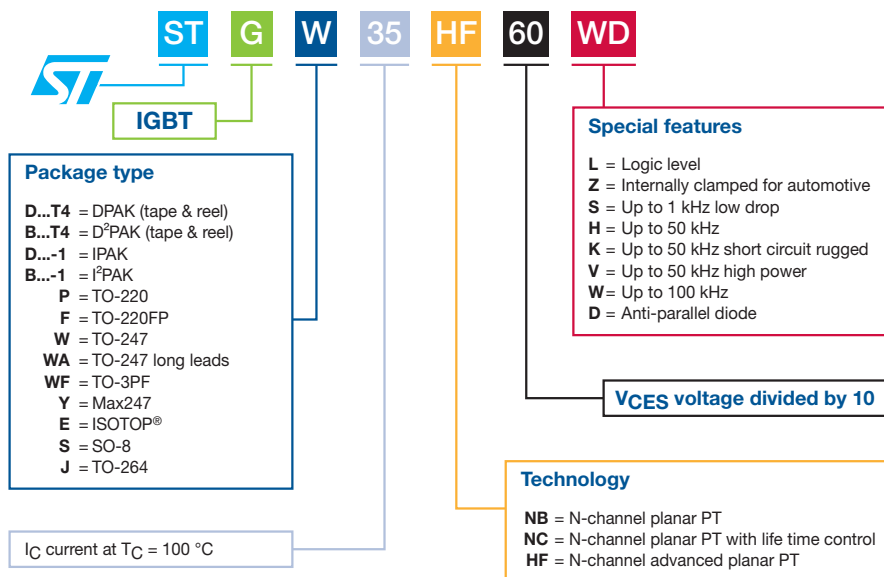

## IGBT module ordering information

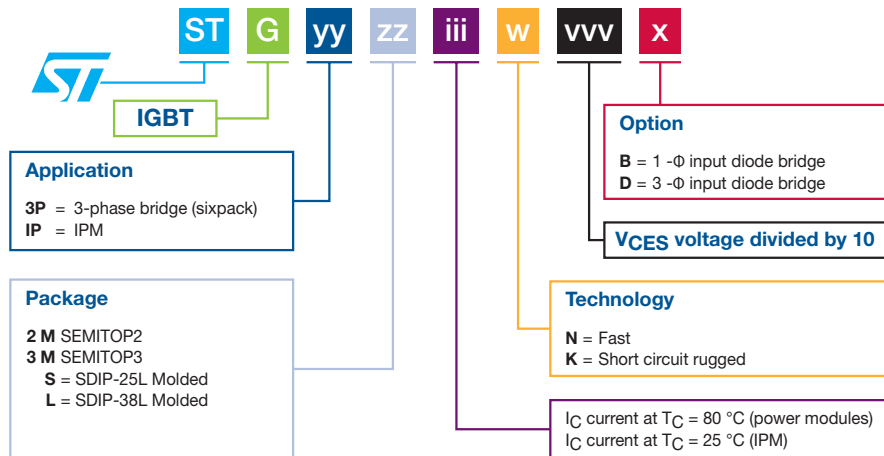

The option digit is present only for IGBT power modules, not IGBT intelligent power modules (IPM)

## Package options

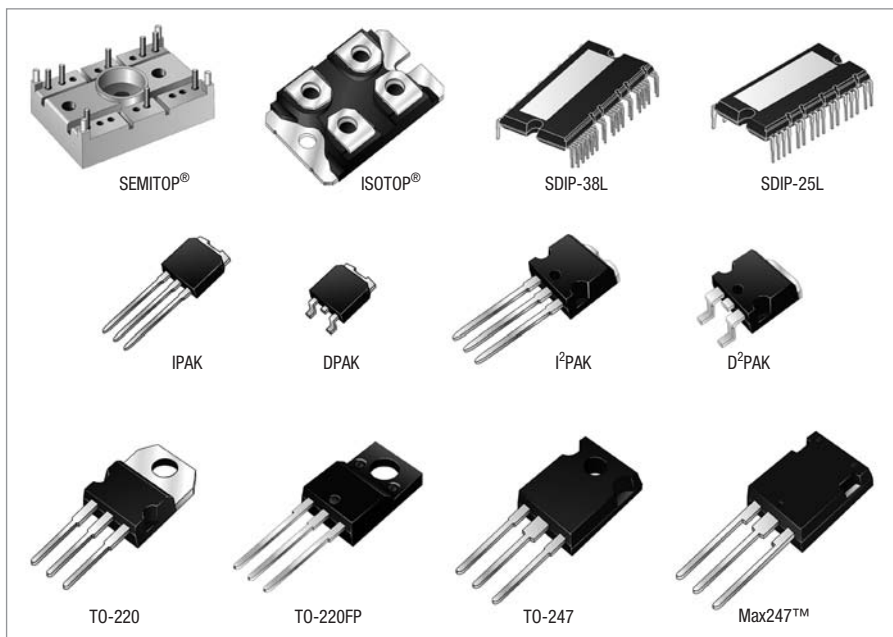

Package images are not to scale



© STMicroelectronics - September 2009 - Printed in Italy - All rights reserved

The STMicroelectronics corporate logo is a registered trademark of the STMicroelectronics group of companies.  
ISOTOP, Max247 and PowerMESH are STMicroelectronics trademarks. SEMITOP is a registered trademark of SEMIKRON  
All other names are the property of their respective owners.

For more information on ST products and solutions,  
visit [www.st.com](http://www.st.com)

Order code: SGIGBTS0909



Recycled and chlorine free paper