

T-39-13

FUJI
ELECTRIC

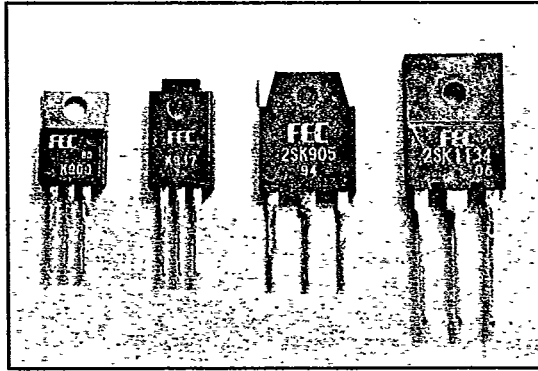

Power MOSFET Advantages:

- F-I Series Low RDS (on)
- F-II Series VGS +/- 30V Reduced
turn off time
- FAP-II Series High avalanced ruggedness
VGS +/- 30V, Reduced turn
off time
- F-III Series Logic level operation, low
RDS (on), high gfs
- F-V Series High diode di/dt rating,
fast diode recovery time,
100 nsec, improved turn on loss.

Power MOSFETs are used on:

- Switching power supplies
- Motor speed controls
- DC/DC converters
- Inverters
- Uninterruptible power supplies
- Fleeker free data monitors
- Electronic ballasts
- Battery chargers

MOSFET Transistors

FUJI Semiconductors • Imported and Distributed by
Collmer Semiconductor, Inc.

14368 PROTON RD • DALLAS, TEXAS 75244 • 214/233-1589
FAX 214/233-0481



Device Type	Ratings			Characteristics				Package
	V _{DSS} (V)	I _D (A)	P _D (W)	R _{DS(ON)} (Ω) (max.)	g _{fs} (S) (typ.)	t _{on} (ns) (max.)	t _{off} (ns) (max.)	
2SK905	50	45	125	0.03	25	240	800	TO3P
2SK1134	50	45	80	0.03	25	255	800	TO3PF
2SK906	100	32	125	0.06	20	180	680	TO3P
2SK900	250	12	80	0.30	9	120	390	TO220
2SK947	250	12	40	0.30	9	120	390	TO220F
2SK948	250	12	100	0.30	9	120	390	TO3P
2SK901	250	20	125	0.15	15	160	780	TO3P
2SK902	250	30	150	0.10	20	310	1550	TO3P
2SK949	500	6	40	1.20	7	100	360	TO220F
2SK950	500	6	80	1.20	7	100	360	TO220
2SK723	500	7	125	1.10	7	65	240	TO3P
2SK859	500	9	125	0.80	5	195	570	TO3P
2SK724	500	10	100	0.67	10	195	570	TO3P
2SK1099	500	10	80	0.67	10	195	570	TO3PF
2SK725	500	15	125	0.38	16	195	570	TO3P
2SK899	500	18	125	0.33	16	195	570	TO3P
2SK897	550	4	40	1.50	5	100	360	TO220F
2SK903	800	3	40	4.00	4	90	340	TO220F
2SK904	800	3	80	4.00	4	90	340	TO220
2SK954	800	3	100	4.00	4	90	340	TO3P
2SK1105	800	3	80	4.00	4	90	340	TO3PF
2SK1384	800	5	80	2.00	6	170	630	TO3PF
2SK955	800	5	125	2.00	6	170	630	TO3P
2SK960	900	3	40	5.00	4	90	340	TO220F
2SK961	900	3	80	5.00	4	90	340	TO220
2SK726	900	3	100	5.00	4	90	340	TO3P
2SK727	900	5	125	2.50	6	170	630	TO3P
2SK1212	900	5	80	2.50	6	170	630	TO3PF

T-39-13

F-II Series 250/450/500 Volts

2SK1221	250	10	80	0.40	4.5	90	225	TO220
2SK1006	450	5	40	1.60	3.0	95	200	TO220F
2SK1007	450	5	60	1.60	3.0	95	200	TO220
2SK1009	450	7	80	1.30	4.0	110	200	TO220
2SK1386	450	7	100	1.30	4.0	110	200	TO3P
2SK1101	450	10	50	0.65	6.5	165	360	TO220F
2SK1011	450	10	100	0.65	6.5	165	360	TO3P
2SK1013	450	13	125	0.60	8.0	215	370	TO3P
2SK1004	450	15	125	0.40	13.0	310	810	TO3P
2SK1222	450	15	125	0.55	8.0	215	370	TO3P
2SK1015	450	18	125	0.45	10.0	260	500	TO3P
2SK1017	450	20	150	0.35	14.0	375	740	TO3P
2SK1019	450	35	300	0.20	20.0	540	1350	TO3PL
2SK1008	500	4.5	60	2.20	3.0	95	200	TO220
2SK1010	500	6	80	1.60	4.0	110	200	TO220
2SK1102	500	10	50	0.90	6.5	165	360	TO220F
2SK1503	500	10	80	0.90	6.5	165	360	TO220
2SK1012	500	10	100	0.90	6.5	165	360	TO3P
2SK1014	500	12	125	0.74	8.0	215	370	TO3P
2SK1016	500	15	125	0.55	10.0	260	500	TO3P
2SK1018	500	18	125	0.45	10.0	260	500	TO3P
2SK1020	500	30	300	0.25	20.0	540	1350	TO3PL

F-II Series 800/900/1000 Volts

2SK951	800	2.5	40	7.00	1.8	90	170	TO220F
2SK952	800	2.5	45	7.00	1.8	90	170	TO220
2SK953	800	2.5	80	7.00	1.8	90	170	TO3P
2SK1211	800	2.5	40	7.00	1.8	90	170	TO3PF
2SK1021	800	3	60	6.00	2.0	128	240	TO220
2SK1023	800	4	60	4.50	4.0	145	255	TO220
2SK1224	800	4	50	4.50	4.0	145	255	TO3PF
2SK1171	800	4	80	4.50	4.0	145	255	TO3P
2SK1081	800	7	125	2.20	4.5	225	380	TO3P
2SK1385	800	9	100	1.50	6.0	425	690	TO3PF

F-II Series 800/900/1000 Volts Continued

Device Type	Ratings			Characteristics				Package
	V _{DSS} (V)	I _D (A)	P _D (W)	R _{DS(ON)} (Ω) (max.)	g _{fs} (S) (typ.)	t _{on} (ns) (max.)	t _{off} (ns) (max.)	
2SK956	800	9	150	1.50	6.0	425	690	TO3P
2SK957	900	2	40	8.50	1.8	90	170	TO220F
2SK958	900	2	45	8.50	1.8	90	170	TO220
2SK959	900	2	80	8.50	1.8	90	170	TO3P
2SK1022	900	2.5	60	7.30	2.0	128	240	TO220
2SK1005	900	3	100	7.00	3.0	110	210	TO3P
2SK1024	900	3.5	60	5.50	4.0	145	255	TO220
2SK1172	900	3.5	80	5.50	4.0	145	255	TO3P
2SK1082	900	6	125	2.80	4.5	225	380	TO3P
2SK962	900	8	150	2.00	6.0	425	690	TO3P
2SK1217	900	8	100	2.00	6.0	425	690	TO3PF
2SK1512	900	10	150	1.20	6.0	240	525	TO3P
2SK1511	1000	5	100	3.00	3.0	121	285	TO3P

F-III Series Logic Level

Device Type	Ratings			Characteristics					Package
	V _{DSS} (V)	I _D (A)	P _D (W)	R _{DS(ON)} (Ω) (max.)		g _{fs} (S) (typ.)	t _{on} (ns) (max.)	t _{off} (ns) (max.)	
				VGS=4V	VGS=10V				
2SK1505	30	35	40	0.037	0.022	17.0	238	720	TO220F
2SK1388	30	35	60	0.037	0.022	17.0	188	720	TO220
2SK1083	60	8	20	0.350	0.220	6.0	55	105	TO220F
2SK1096	60	13	30	0.190	0.120	11.0	60	180	TO220F
2SK1086	60	20	35	0.110	0.070	15.0	75	310	TO220F
2SK1387	60	35	40	0.056	0.035	18.0	99	760	TO220F
2SK1089	60	35	80	0.056	0.035	18.0	99	760	TO3P
2SK1389	60	50	125	0.040	0.025	36.0	230	850	TO3P
2SK1390	60	50	80	0.040	0.025	36.0	230	850	TO3PF
2SK1084	100	5	20	0.700	0.500	4.5	53	85	TO220F
2SK1097	100	8	30	0.390	0.280	7.0	60	170	TO220F
2SK1087	100	12	35	0.240	0.170	10.0	93	320	TO220F
2SK1090	100	20	80	0.120	0.080	20.0	83	680	TO3P
2SK1085	150	3	20	1.170	0.900	3.0	50	120	TO220F
2SK1098	150	6	30	0.650	0.500	6.0	75	170	TO220F
2SK1088	150	9	35	0.400	0.300	10.0	75	275	TO220F
2SK1091	150	15	80	0.200	0.150	18.0	83	680	TO3P
2SK1144	250	20	50	0.165	0.150	25.0	135	970	TO220F

F-V Series (FRED MOSFETs)

2SK1276	250	20	100	0.20	12.0	125	450	TO3P
2SK1277	250	30	150	0.12	20.0	260	900	TO3P
2SK1278	500	10	100	1.10	8.0	130	440	TO3P
2SK1279	500	15	125	0.58	13.0	195	840	TO3P
2SK1280	500	18	150	0.50	15.0	270	720	TO3P

FAP-II Series (High Avalanche Ruggedness)

2SK1008-01	500	4.5	60	2.20	3.0	95	200	TO220
2SK1010-01	500	6	80	1.60	4.0	110	200	TO220
2SK1012-01	500	10	100	0.90	6.5	165	360	TO3P
2SK1014-01	500	12	125	0.74	8.0	215	370	TO3P
2SK1016-01	500	15	125	0.55	10.0	260	500	TO3P
2SK1018-01	500	18	125	0.45	10.0	260	500	TO3P
2SK1554-01	650	3	30	4.50	3.0	90	188	TO220F
2SK1553-01	650	5	40	2.50	5.0	85	280	TO220F
2SK951-01	800	2.5	40	7.00	1.8	90	170	TO220F
2SK1023-01	800	4	60	4.50	4.0	145	255	TO220
2SK1171-01	800	4	80	4.50	4.0	145	255	TO3P
2SK1081-01	800	7	125	2.20	4.5	225	380	TO3P
2SK956-01	800	9	150	1.50	6.0	425	690	TO3P
2SK957-01	900	2	40	8.50	1.8	90	170	TO220F
2SK1548-01	900	3.5	40	5.50	4.0	145	255	TO220F
2SK1024-01	900	3.5	60	5.50	4.0	145	255	TO220
2SK1172-01	900	3.5	80	5.50	4.0	145	255	TO3P
2SK1082-01	900	6	125	2.80	4.5	225	380	TO3P
2SK962-01	900	8	150	2.00	6.0	425	690	TO3P

MOSFET Transistors

T-39-13

MOSFET Modules

Device Type	Ratings			Characteristics				Package
	V _{DSS} (V)	I _D (A)	P _D (W)	R _{DS(ON)} (Ω) (max.)	g _{fs} (S) (typ.)	t _{on} (ns) (max.)	t _{off} (ns) (max.)	
2MI50F-050	500	50	400	0.110	45	530	780	MODULE
2MI50S-050	500	50	400	0.110	45	530	780	MODULE
2MI100F-025	250	100	400	0.032	55			MODULE
2MI100F-050	500	100	800	0.062	105	185	630	M210
2MI200F-025	250	200	800	0.015	150	175	600	M210
6MI15FS-050	500	15	60	0.400	13	130	560	SIL
6MI20FS-025	250	20	40	0.160	12	80	300	SIL

TO-220

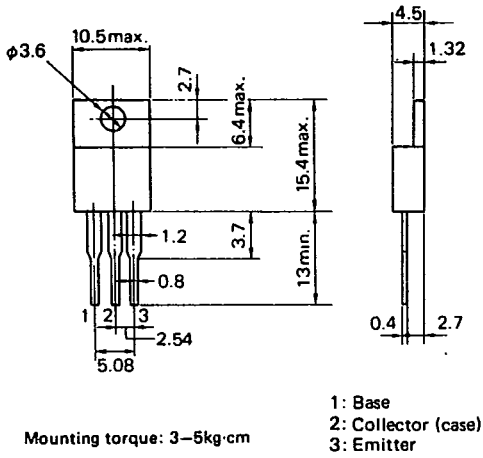

TO-3P

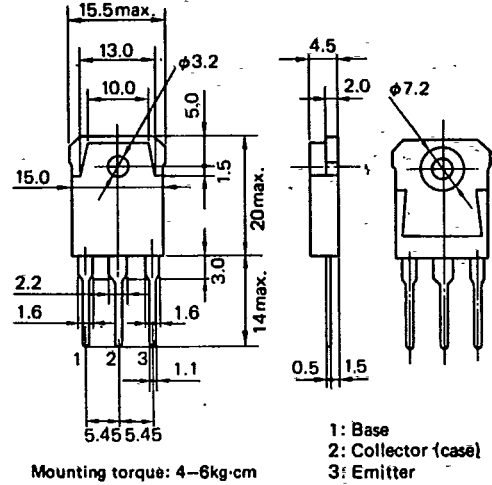

TO-220F (Full molded package)

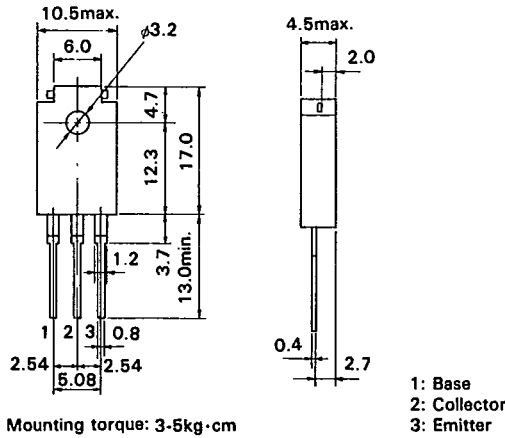

TO-3PF (Full molded package)

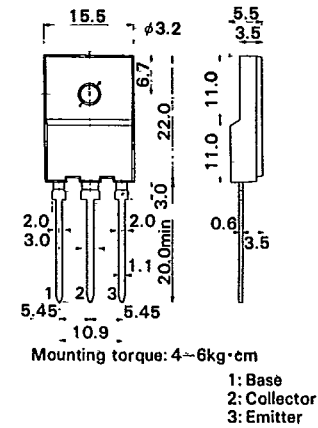

M210

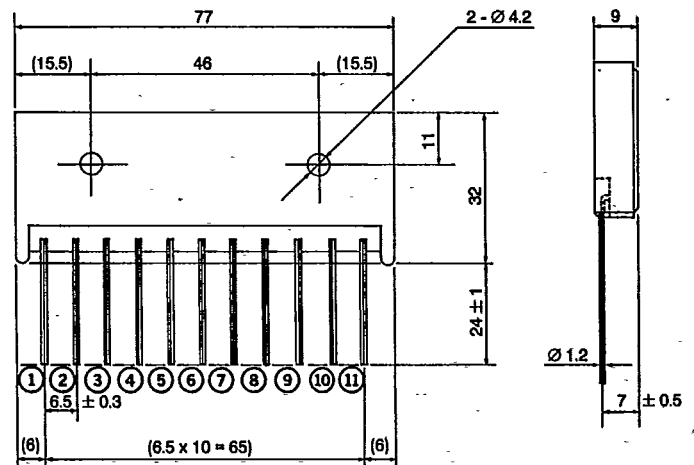
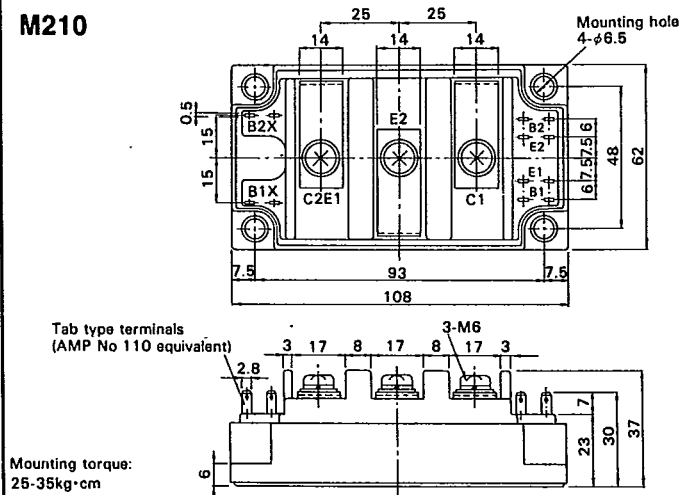

COLLMER SEMICONDUCTOR, INC reserves the right to make changes in these specifications at any time and without notice in order to supply the best product possible

©1990 • COLLMEER SEMICONDUCTOR, INC. • Printed in U.S.A.

COLLMER SEMICONDUCTOR INC 34E D 2238792 0001560