

LMP7312

*LMP7312 Precision SPI-Programmable AFE with Differential/Single-Ended
Input/Output*

Searchdatasheet.com



Literature Number: SNOSB32A

LMP7312

Precision SPI-Programmable AFE with Differential/Single-Ended Input/Output

General Description

The LMP7312 is a digitally programmable variable gain amplifier/attenuator. Its wide input voltage range and superior precision make it a prime choice for applications requiring high accuracy such as data acquisition systems for IO modules in programmable logic control (PLC). The LMP7312 provides a differential output to maximize dynamic range and signal to noise ratio, thereby reducing the overall system error. It can also be configured to handle single ended input data converters by means of the V_{OCM} pin (see application section for details). The inputs of LMP7312 can be configured in attenuation mode to handle large input signals of up to +/- 15V, as well as in amplification mode to handle current loops of 0-20mA and 4-20mA. The LMP7312 is equipped with a null switch to evaluate the offset of the internal amplifier. A guaranteed 0.035% maximum gain error (for all gains) and a maximum gain drift of 5ppm over the extended industrial temperature range (-40° to 125°C) make the LMP7312 very attractive for high precision systems even under harsh conditions. A low input offset voltage of 100µV and low voltage noise of 3µVpp give the LMP7312 a superior performance. The LMP7312 is fully specified from -40° to 125°C and is available in SOIC-14 package.

Features

Typical Values, $T_A = 25^\circ\text{C}$, $V^+ = 5\text{V}$, $V^- = 0\text{V}$.

■ Gain bandwidth	1 MHz
■ Input voltage range ($G = 0.096 \text{ V/V}$)	-15V to +15V
■ Core op-amp input offset voltage	100 µV (max)
■ Supply current	2 mA (max)
■ Gain (Attenuation Mode)	0.096 V/V, 0.192 V/V 0.384 V/V, 0.768 V/V
■ Gain (Amplification Mode)	1 V/V, 2 V/V
■ Gain Error	0.035% (max)
■ Core op-amp PSRR	90 dB (min)
■ CMRR	80 dB (min)
■ Adjustable output common mode	1V to 4V
■ Temperature range	-40 to 125°C
■ Package	14-Pin SOIC

Applications

- Signal conditioning AFE
±10V; ±5V; 0-5V; 0-10V; 0-20mA; 4-20mA
- Data Acquisition systems
- Motor control
- Instrument and process control
- Remote sensing
- Programmable automation control

Typical Application

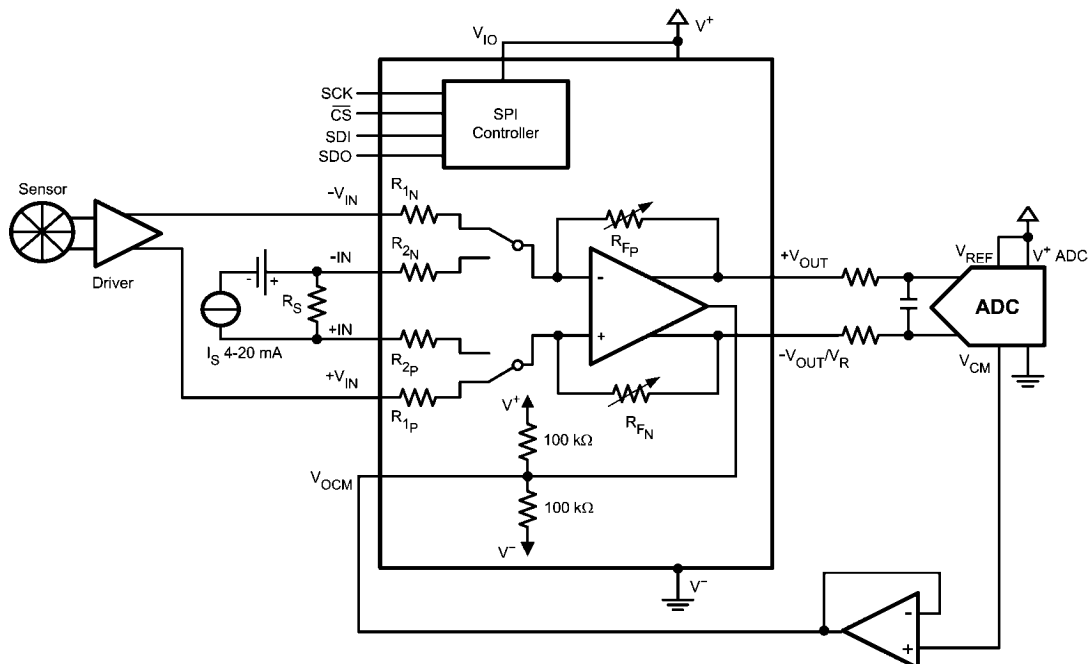

30075513

LMP™ is a trademark of National Semiconductor Corporation.

Absolute Maximum Ratings (Note 1)

If Military/Aerospace specified devices are required, please contact the National Semiconductor Sales Office/ Distributors for availability and specifications.

ESD Rating (Note 2)

Human Body Model	2000V
Machine Body Model	150V
Charge device Model	1000V
Analog Supply Voltage ($V_S = V^+ - V^-$)	6V
Digital Supply Voltage ($V_{DIO} = V_{IO} - V^-$)	6V
Attenuation pins $-V_{IN}$, $+V_{IN}$ referred to V^-	$\pm 17.5V$
Amplification pins $-IN$, $+IN$ referred to V^-	$\pm 10V$
Voltage at all other pins referred to V^-	6V
Storage Temperature Range	$-65^\circ C$ to $150^\circ C$

For soldering specification:

see product folder at www.national.com and www.national.com/ms/MS/MS-SOLDERING.pdf

Junction Temperature

$150^\circ C$

Operating Ratings (Note 1)

Analog Supply Voltage ($V_S = V^+ - V^-$), $V^- = 0V$	4.5V to 5.5V
Digital Supply Voltage ($V_{DIO} = V_{IO} - V^-$), $V^- = 0V$	2.7V to 5.5V
Attenuation pins $-V_{IN}$, $+V_{IN}$ referred to V^-	$-15V$ to $15V$
Amplification pins $-IN$, $+IN$ referred to V^-	$-2.35V$ to $7.35V$
Temperature Range (Note 3)	$-40^\circ C$ to $125^\circ C$
Package Thermal Resistance (Note 3) SOIC-14	$145^\circ C/W$

5V Electrical Characteristics (Note 4)

Unless otherwise specified, all limits guaranteed for $T_A = 25^\circ C$, $V^+ = 5V$, $V_{IO} = 5V$, $V^- = 0V$, $G = 0.192 V/V$, $V_{CM_ATT} = (+V_{IN} + (-V_{IN}))/2$, $V_{CM_AMP} = (+IN + (-IN))/2$. Differential output configuration. SE = Single Ended Output, DE = Differential Output. **Boldface** limits apply at the temperature extremes.

Symbol	Parameter	Conditions	Min (Note 6)	Typ (Note 5)	Max (Note 6)	Units
V_{OS}	Core op-amp Input Offset Voltage	Nulling Switch Mode, DE, $V_{OCM} = 1V$; Nulling switch Mode, SE, $-V_{OUT}/V_R = 1V$	-100 -250		100 250	μV
		Nulling Switch Mode, DE, $V_{OCM} = 4V$; Nulling Switch Mode, SE, $-V_{OUT}/V_R = 4V$	-100 -250		100 250	
TCV_{OS}	Core op-amp Input Offset Voltage (Note 7)	Nulling Switch Mode, DE, $V_{OCM} = 1V$; Nulling Switch Mode, SE, $-V_{OUT}/V_R = 1V$	-3	± 1.5	3	$\mu V/^\circ C$
		Nulling Switch Mode, DE, $V_{OCM} = 4V$; Nulling Switch Mode, SE, $-V_{OUT}/V_R = 4V$	-3	± 1.5	3	
A_v	Gain Error	All gains, $R_L = 10 k\Omega$, $C_L = 50pF$, SE / DE	-0.035 -0.045		0.035 0.045	%
	Gain Drift	SE / DE	-5	± 1	5	ppm/ $^\circ C$
e_n	Core op-amp Voltage Noise Density	RTI, Nulling Switch Mode, $f = 10 kHz$		7.25		nV/\sqrt{Hz}
	Core op-amp Peak to Peak Voltage Noise	RTI, Nulling Switch Mode, $f = 0.1Hz$ to $10Hz$		3		μV_{PP}
I_{VA}	Analog Supply Current	$+V_{IN} = -V_{IN} = V_{OCM}$			2	mA
I_{VIO}	Digital Supply Current	Without any load connected to SDO pin			120	μA
R_{IN_CM}	CM Input Resistance	$G = 0.192 V/V$		62.08		$k\Omega$
		$G = 1 V/V$		40		
R_{IN_DIFF}	Differential Input Resistance	$G = 0.192 V/V$		248.3		$k\Omega$
		$G = 1 V/V$		160		
$CMRR$	DC Common Mode Rejection Ratio	$G = 0.096V/V$, $-15V < V_{CM_ATT} < 15V$, SE / DE	80 77			dB
		$G = 0.192V/V$, $-11.4V < V_{CM_ATT} < 15V$, SE / DE				
		$G = 0.384V/V$, $-6V < V_{CM_ATT} < 11V$, SE / DE				
		$G = 0.768V/V$, $-3V < V_{CM_ATT} < 8V$, SE / DE				
		$G = 1V/V$, $-2.3V < V_{CM_AMP} < 7.3V$, SE / DE				
		$G = 2V/V$, $-1.15V < V_{CM_AMP} < 6.15V$, SE / DE.				
$PSRR$	Core op-amp DC Power Supply Rejection Ratio	Nulling Switch Mode, $4.5V < V^+ < 5.5V$	90			dB

Symbol	Parameter	Conditions	Min (Note 6)	Typ (Note 5)	Max (Note 6)	Units
V_{OCM_OS}	V_{OCM} Output Offset (Note 8)	$V_{OCM} = 2.5\text{ V}$	-20		20	mV
V_{OUT}	Positive Output Voltage Swing	$R_L = 10\text{ k}\Omega$, $C_L = 50\text{ pF}$, $+V_{IN} = 15\text{ V}$, $-V_{IN} = -15\text{ V}$			$V_{+} - 0.2$	V
	Negative Output Voltage Swing	$R_L = 10\text{ k}\Omega$, $C_L = 50\text{ pF}$, $+V_{IN} = -15\text{ V}$, $-V_{IN} = 15\text{ V}$	$V_{-} + 0.2$			
I_{OUT}	Short circuit current	$+V_{IN} = -V_{IN} = 2.5\text{ V}$, $+V_{OUT}$, $-V_{OUT}/V_R$ connected individually to either V_{+} or V_{-}	10			mA
	Current limitation	Internal current limiter			55	
GBW	Bandwidth	Attenuation Mode, $G = 0.096\text{ V/V}$, $R_L = 10\text{ k}\Omega$, $C_L = 50\text{ pF}$		1.2		MHz
		Attenuation Mode, $G = 0.192\text{ V/V}$, $R_L = 10\text{ k}\Omega$, $C_L = 50\text{ pF}$		1.0		
		Attenuation Mode, $G = 0.384\text{ V/V}$, $R_L = 10\text{ k}\Omega$, $C_L = 50\text{ pF}$		560		kHz
		Attenuation Mode, $G = 0.768\text{ V/V}$, $R_L = 10\text{ k}\Omega$, $C_L = 50\text{ pF}$		310		
		Amplification Mode, $G = 1\text{ V/V}$, $R_L = 10\text{ k}\Omega$, $C_L = 50\text{ pF}$		530		kHz
		Amplification Mode, $G = 2\text{ V/V}$, $R_L = 10\text{ k}\Omega$, $C_L = 50\text{ pF}$		280		
SR	Slew Rate	$R_L = 10\text{ k}\Omega$, $C_L = 50\text{ pF}$ (Note 9)		1.4		V/ μsec
THD+N	Total Harmonic Distorsion + Noise	$V_{out} = 4.096\text{ V}_{pp}$, $f = 1\text{ KHz}$, $R_L = 10\text{ k}\Omega$		0.0026		%

Electrical Characteristics (Serial Interface) (Note 4)

Unless otherwise specified. All limits guaranteed for $T_A = 25^\circ\text{C}$, $V_{+} = 5\text{ V}$, $V_{-} = 0\text{ V}$, $2.7\text{ V} < V_{IO} < 5.5\text{ V}$

Symbol	Parameter	Conditions	Min (Note 6)	Typ (Note 5)	Max (Note 6)	Units
V_{IL}	Input Logic Low Threshold				0.8	V
V_{IH}	Input Logic High Threshold (SDO pin)		2			V
V_{OL}	Output logic Low Threshold (SDO pin)	$I_{SDO} = 100\mu\text{A}$			0.2	V
		$I_{SDO} = 2\text{ mA}$			0.4	
V_{OH}	Output logic High Threshold	$I_{SDO} = 100\mu\text{A}$	$V_{IO} - 0.2$			V
		$I_{SDO} = 2\text{ mA}$	$V_{IO} - 0.6$			
t_1	High Period, SCK	(Note 10)	100			ns
t_2	Low Period, SCK	(Note 10)	100			ns
t_3	Set Up Time, $\overline{\text{CS}}$ to SCK	(Note 10)	50			ns
t_4	Set Up Time, SDI to SCK	(Note 10)	30			ns
t_5	Hold Time, SCK to SDI	(Note 10)	10			ns
t_6	Prop. Delay, SCK to SDO	(Note 10)			60	ns
t_7	Hold Time, SCK Transition to $\overline{\text{CS}}$ Rising Edge	(Note 10)	50			ns
t_8	$\overline{\text{CS}}$ Inactive	(Note 10)	100			ns
t_9	Hold Time, SCK Transition to $\overline{\text{CS}}$ Falling Edge	(Note 10)	10			ns
t_R/t_F	Signal Rise and Fall Times	(Note 10)	1.5		5	ns

Note 1: Absolute Maximum Ratings indicate limits beyond which damage to the device may occur. Operating Ratings indicate conditions for which the device is intended to be functional, but for which specific performance is not guaranteed. For guaranteed specifications and the test conditions, see Electrical Characteristics.

Note 2: Human Body Model, applicable std. MIL-STD-883, Method 3015.7. Machine Model, applicable std. JESD22-A115-A (ESD MM std. of JEDEC). Field-Induced Charge-Device Model, applicable std. JESD22-C101-C (ESD FICDM std. of JEDEC).

Note 3: The maximum power dissipation is a function of $T_{J(max)}$, θ_{JA} . The maximum allowable power dissipation at any ambient temperature is: $PD(max) = (T_{J(max)} - T_A) / \theta_{JA}$. All numbers apply for packages soldered directly onto a PC Board.

Note 4: Electrical Table values apply only for factory testing conditions at the temperature indicated. Factory testing conditions result in very limited self-heating of the device such that $T_J = T_A$. No guarantee of parametric performance is indicated in the electrical tables under conditions of internal self-heating where $T_J > T_A$.

Note 5: Typical values represent the most likely parametric norm at the time of characterization. Actual typical values may vary over time and will also depend on the application and configuration. The typical values are not tested and are not guaranteed on shipped production material.

Note 6: All limits are guaranteed by testing, design, or statistical analysis.

Note 7: Offset voltage temperature drift is determined by dividing the change in V_{OS} at the temperature extremes by the total temperature change.

Note 8: V_{OCM_OS} is the difference between the Output Common mode voltage $(+V_{OUT} + (-V_{OUT}/V_R))/2$ and the Voltage on the V_{OCM} pin.

Note 9: The number specified is the average of rising and falling slew rates and is measured at 90% to 10%.

Note 10: Load for these tests is shown in the Test Circuit Diagram.

Test Circuit Diagram

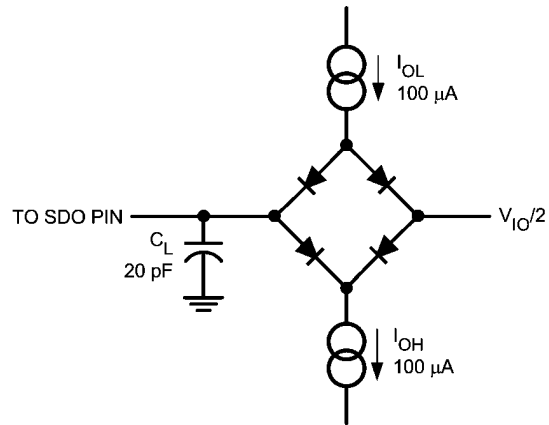

30075510

Timing Diagram

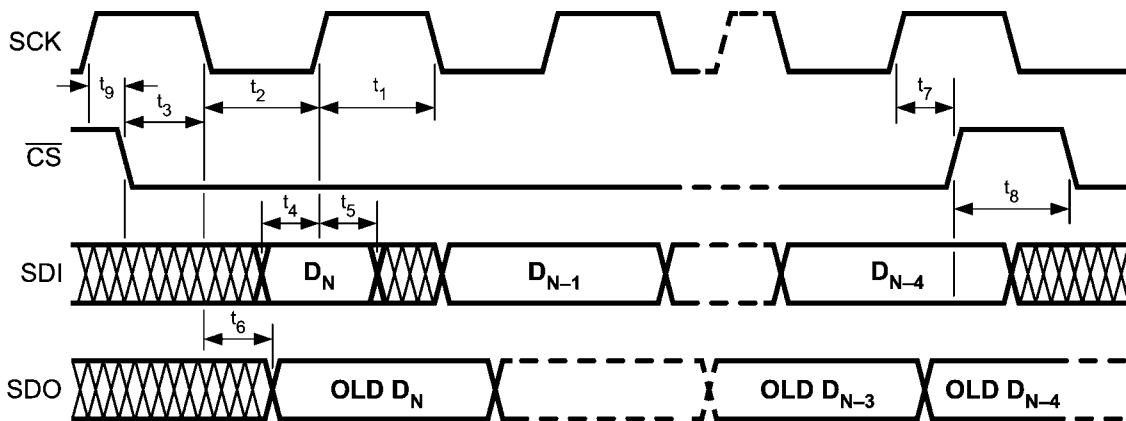

30075509

Connection Diagram

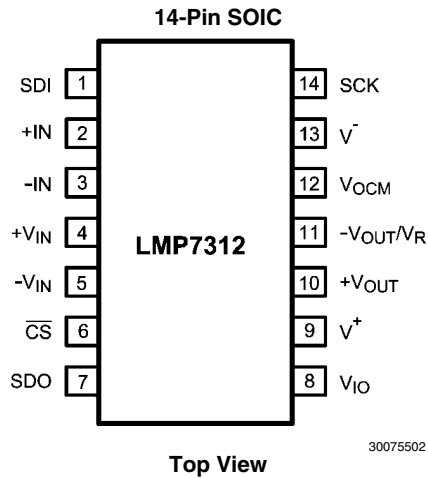

Pin Descriptions

Pin	Name	Description
1	SDI	SPI data IN
2	+IN	Non-inverting input of Amplification pair
3	-IN	Inverting input of Amplification pair
4	+V _{IN}	Non-inverting input of Attenuation pair
5	-V _{IN}	Inverting input of Attenuation pair
6	$\overline{\text{CS}}$	SPI chip select
7	SDO	SPI data OUT
8	V _{IO}	SPI supply voltage
9	V ⁺	Positive supply voltage
10	+V _{OUT}	Non-inverting output
11	-V _{OUT} /V _R	Inverting output in differential output mode, reference input in single-ended operation mode
12	V _{OCM}	Output common mode voltage in DE
13	V ⁻	Negative supply voltage, reference for both Analog and Digital supplies
14	SCK	SPI Clock

Ordering Information

Package	Part Number	Package Marking	Transport Media	NSC Drawing
14-Pin SOIC	LMP7312MA	LMP7312MA	95 Units/Rail	M14A
	LMP7312MAX		2.5k units Tape and Reel	

Typical Performance Characteristics

Unless otherwise specified, $T_A = 25^\circ\text{C}$, $V_+ = 5\text{V}$, $V_{IO} = 5\text{V}$, $V_- = 0\text{V}$, $V_{\text{CM_ATT}} = (+V_{\text{IN}} + (-V_{\text{IN}}))/2$, $V_{\text{CM_AMP}} = (+\text{IN} + (-\text{IN}))/2$. $R_L = 10\text{k}\Omega$, $C_L = 50\text{pF}$, Differential output configuration.

Offset Voltage distribution (PMOS)

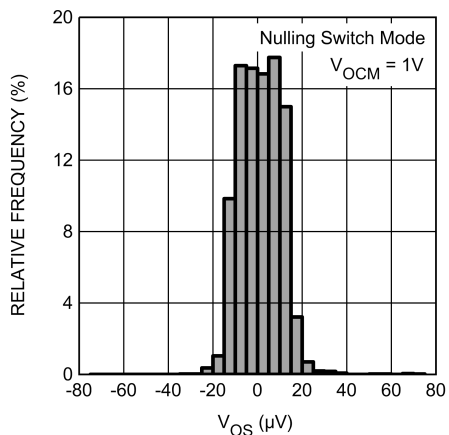

30075546

Offset Voltage distribution (NMOS)

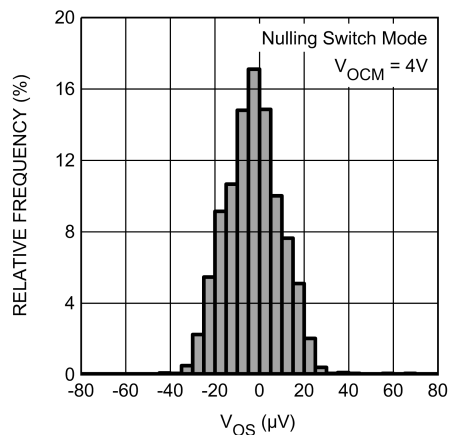

30075547

TCV_{OS} distribution (PMOS)

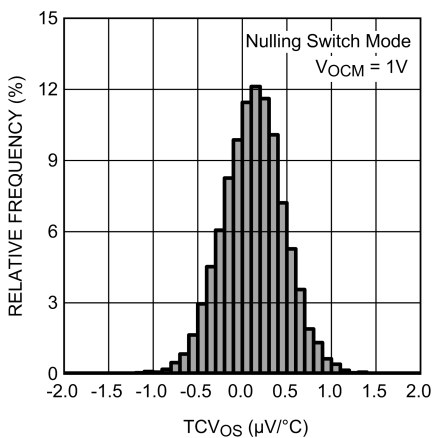

30075548

TCV_{OS} distribution (NMOS)

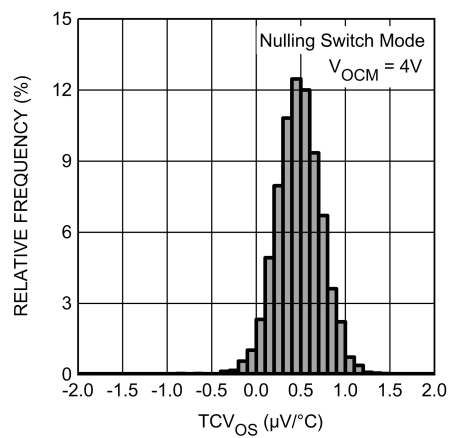

30075549

Noise vs. Frequency (Core op-amp)

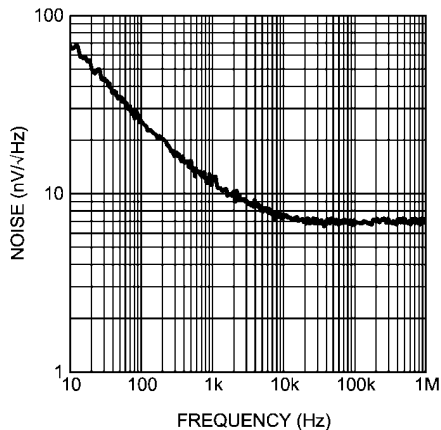

30075519

0.1Hz to 10Hz Noise (Core op-amp)

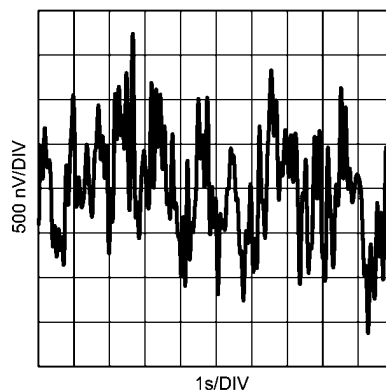

30075520

Gain vs. Frequency (Attenuation Mode)

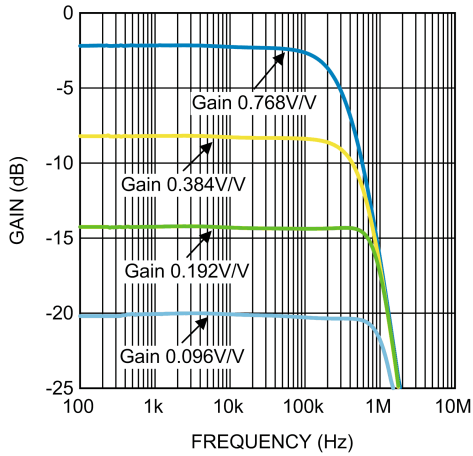

30075521

Gain vs. Frequency (Amplification Mode)

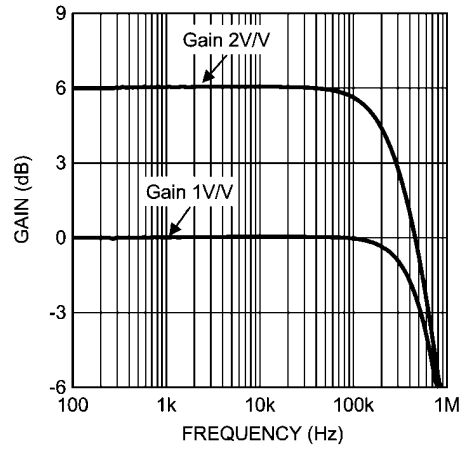

30075522

CMRR vs. Frequency (Attenuation Mode)

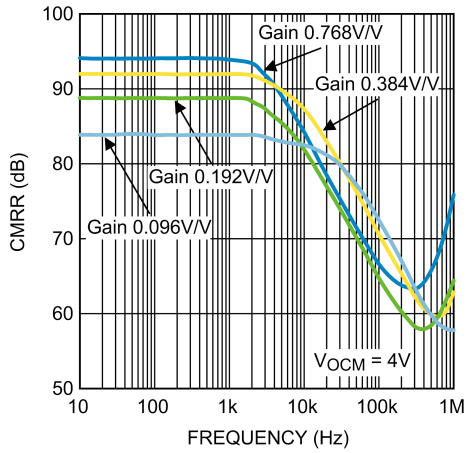

30075536

CMRR vs. Frequency (Amplification Mode)

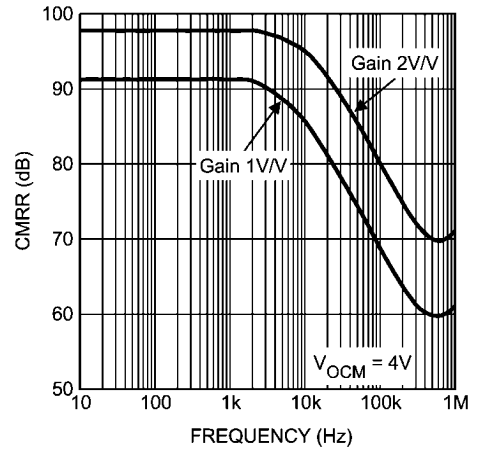

30075537

PSRR (Core op-amp)

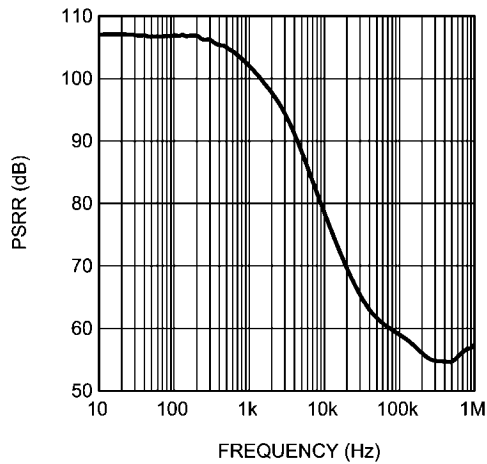

30075523

Vos vs. Input Common Mode Voltage

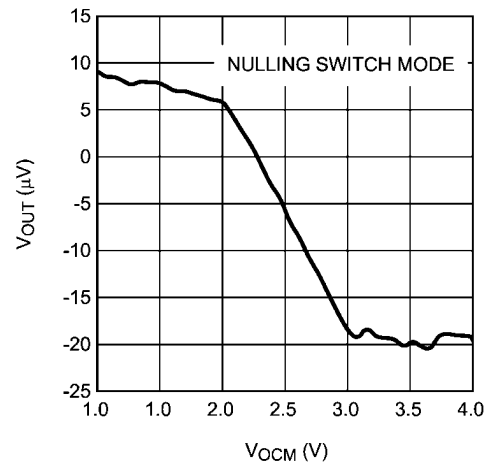

30075545

Small signal step (Attenuation Mode)

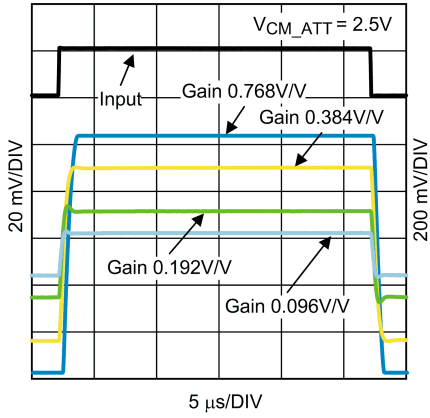

30075524

Small signal step (Amplification Mode)

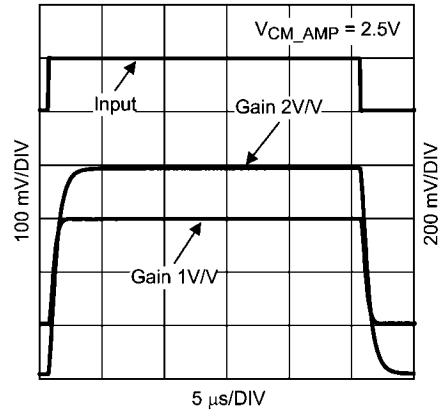

30075525

Large signal step (Attenuation Mode)

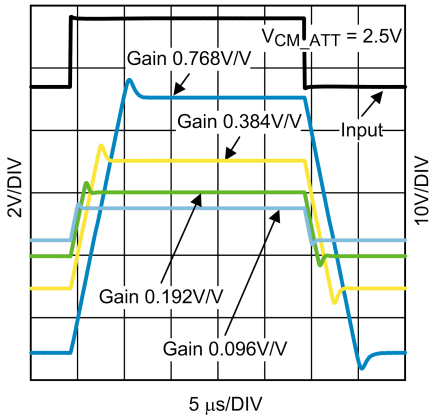

30075526

Large signal step (Amplification Mode)

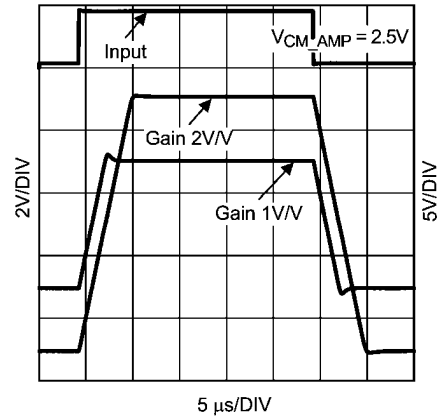

30075527

Settling time – Rise (Attenuation Mode)

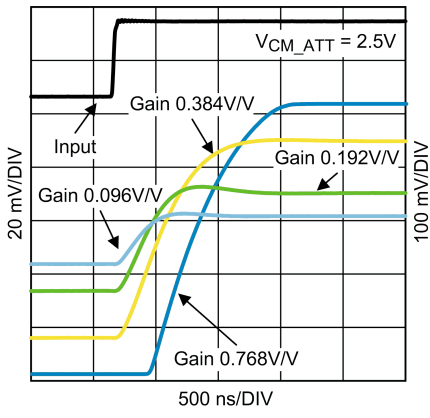

30075528

Settling time – Rise (Amplification Mode)

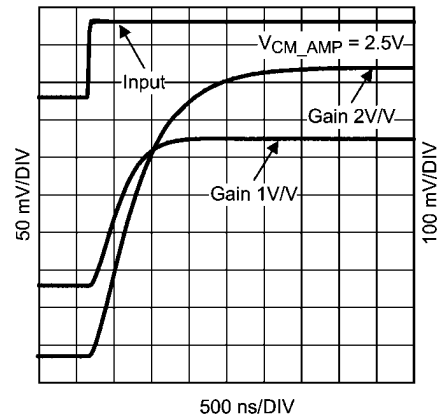

30075529

Settling time – Fall (Attenuation Mode)

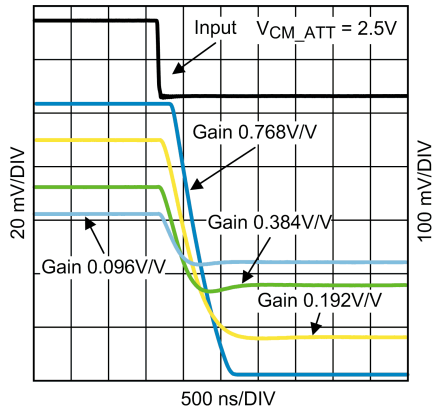

30075530

Settling time – Fall (Amplification Mode)

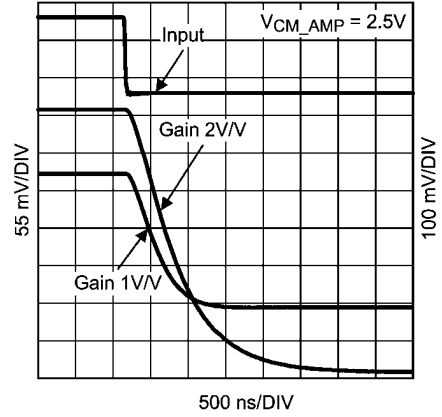

30075531

Gain change (Attenuation Mode)

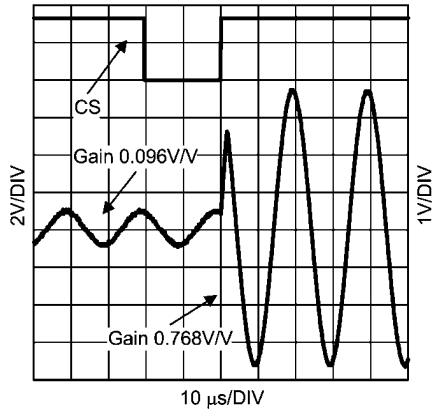

30075532

Gain change (Amplification Mode)

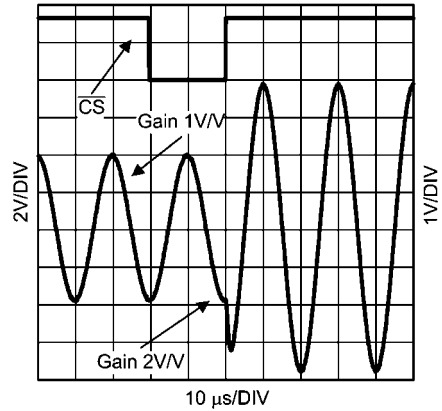

30075533

THD + N (Attenuation Mode)

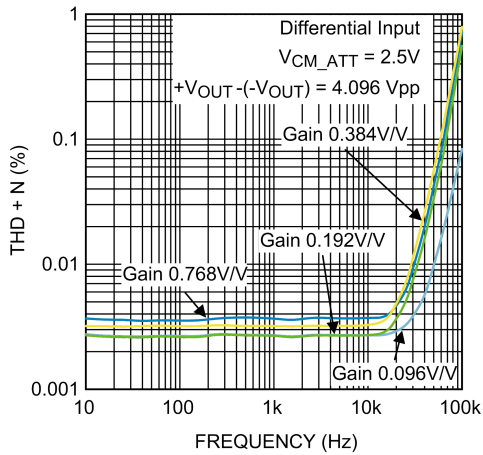

30075534

THD + N (Amplification Mode)

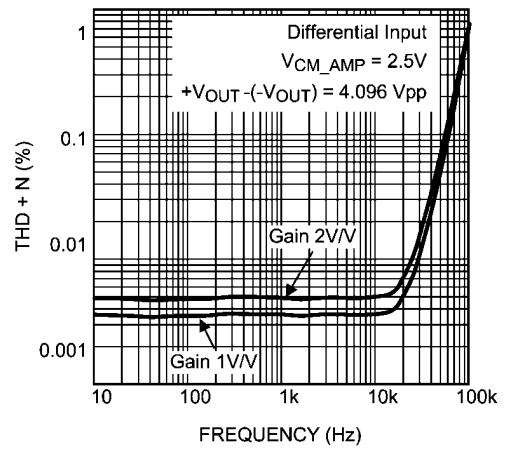

30075535

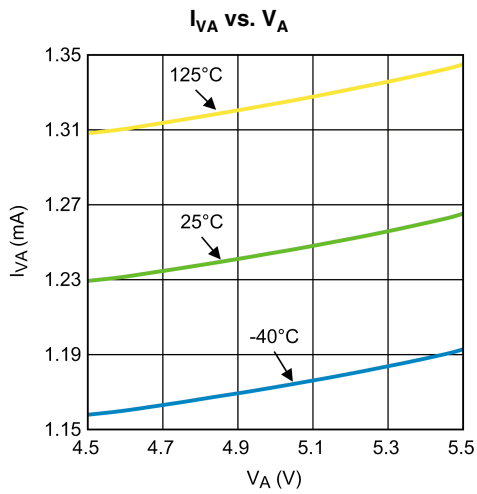

30075551

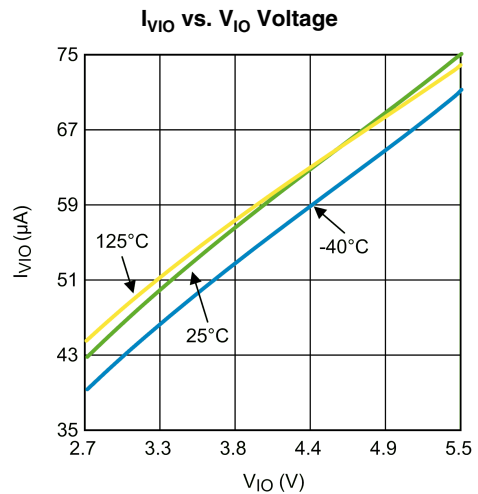

30075550

Short Circuit Current +V_{OUT} vs. Temperature

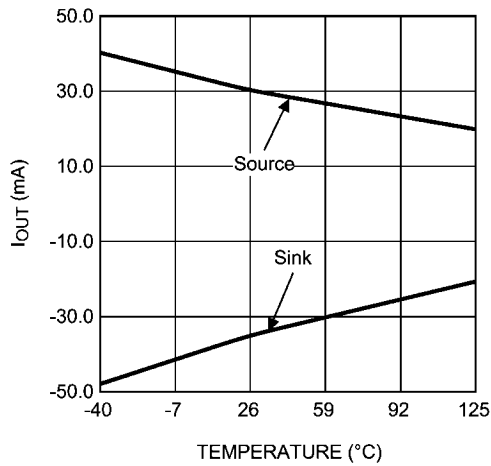

30075541

Short Circuit Current -V_{OUT} vs. Temperature

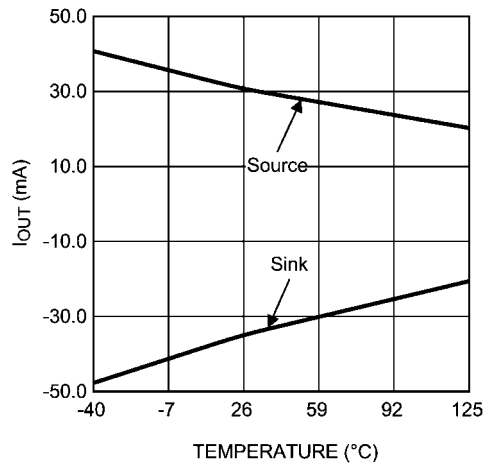

30075540

Output voltage swing +V_{OUT} vs. Output current

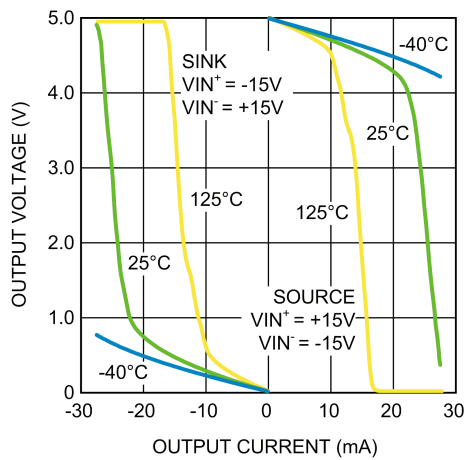

30075543

Output voltage swing -V_{OUT} vs. Output current

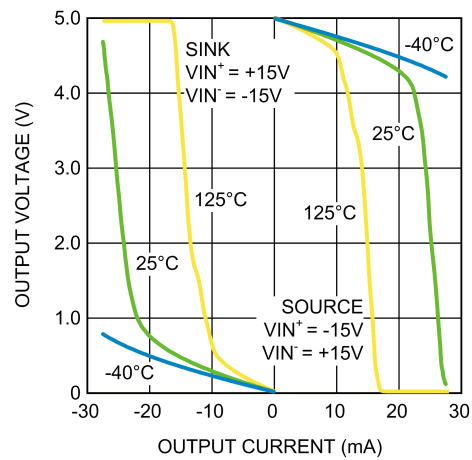

30075542

SDO sink current vs. SDO Voltage

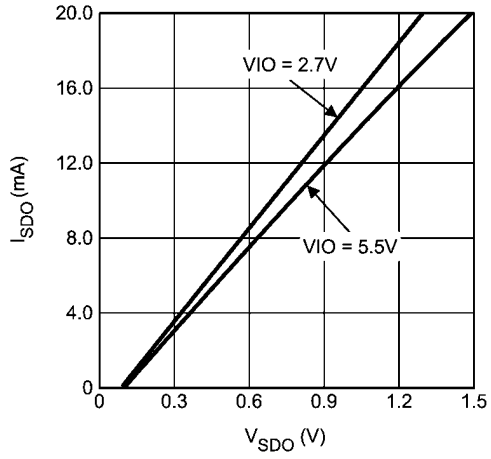

30075539

SDO source current vs. SDO Voltage

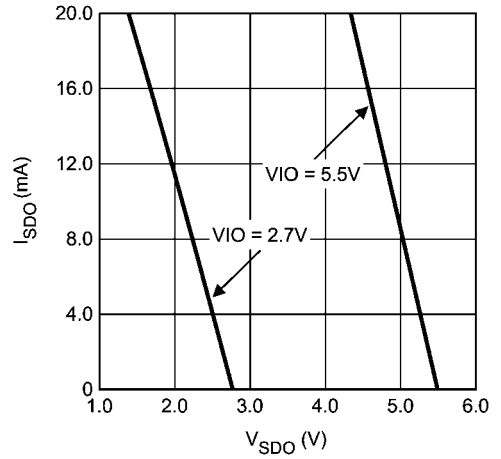

30075538

Application Section

GENERAL DESCRIPTION

The LMP7312 is a single supply programmable gain difference amplifier with two input pairs: Attenuation pair ($-V_{IN}$, $+V_{IN}$) and Amplification pair ($-IN$, $+IN$). The output can be configured in both single-ended and differential modes with the output common mode voltage set by the user. The input selection, the gains and the mode of operation of the LMP7312 are controlled through a 4-wire SPI interface (SCK, \overline{CS} , SDI, SDO). These features combined make the LMP7312 a very easy interface between the analog high voltage industrial buses and the low voltage digital converters.

OUTPUT MODE CONFIGURATION

The LMP7312 is able to work in both single ended and differential output mode. The selection of the mode is made through the V_{OCM} (output common mode voltage) pin.

Differential Output

This mode of operation is enabled when the output common mode voltage pin (V_{OCM}) is connected to a voltage higher than

1V, for instance the common mode voltage supplied by an ADC, (Figure 1) or a voltage reference. If the V_{OCM} pin is floating an internal voltage divider biases it at the half supply voltage. In this configuration the output signals are set on the V_{OCM} voltage level.

Single-Ended Output

This mode of operation is enabled when the V_{OCM} pin is tied to a voltage less than 0.5 V, for example to ground. In this mode of operation the LMP7312 behaves as a difference amplifier, where the $+V_{OUT}$ pin is the single-ended output while the $-V_{OUT}/V_R$ is the reference voltage.

1. In the case of bipolar input signal the non inverting output will be connected to an external reference through a buffer (Figure 2).
2. In the case of unipolar input signal the non inverting output will be connected to ground (Figure 3).

In both cases the inverting output pin is configured as an input pin.

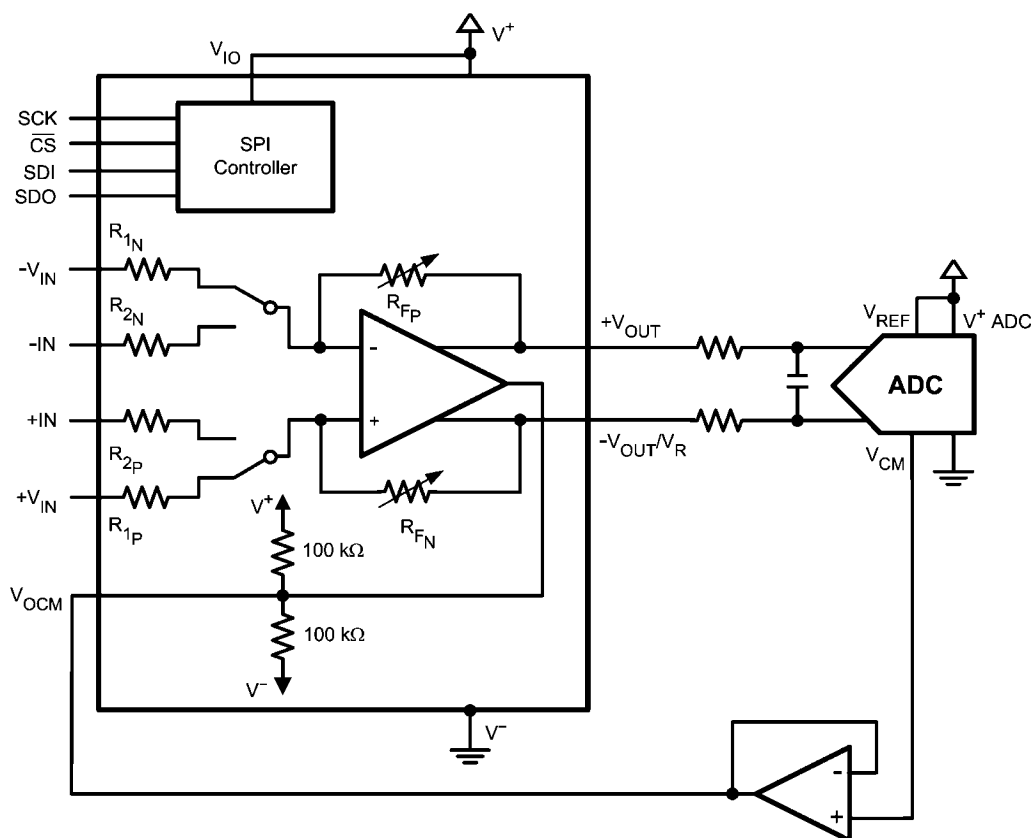

30075503

FIGURE 1. Differential ADC Interfacing with V_{CM} provided by the ADC

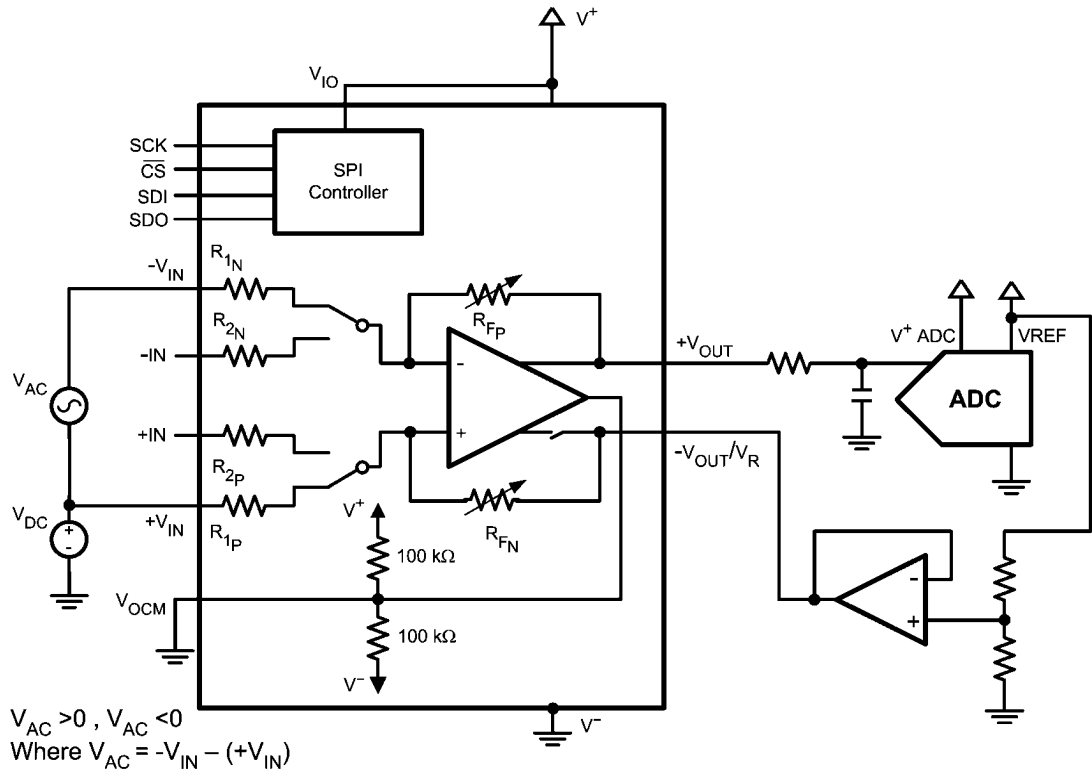

30075504

FIGURE 2. Bipolar Input Signal to Single-Ended ADC Interface

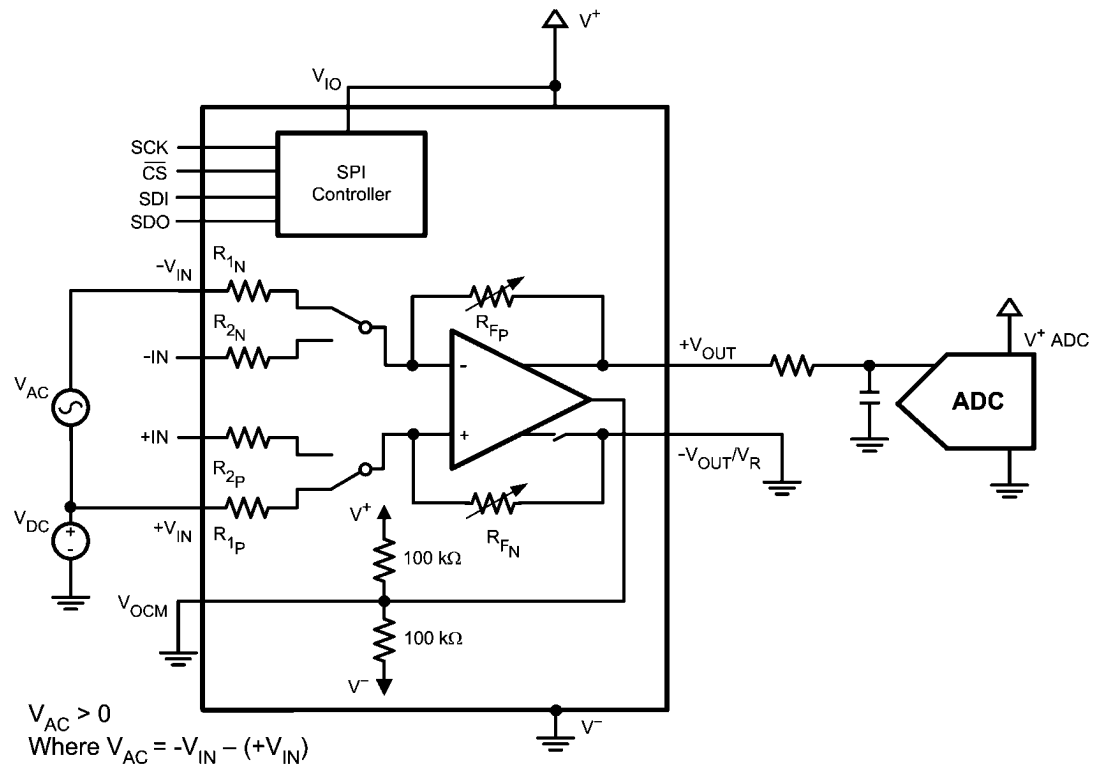

30075505

FIGURE 3. Unipolar Input Signal to Single-Ended ADC Interface

INPUT VOLTAGE RANGE

The LMP7312 has an internal OpAmp with rail-to-rail input voltage range capability. The requirement to stay within the V⁻ and V⁺ rail at the OpAmp input translates in an Input Voltage Range specification as explained in this application section.

Differential Output

Considering a single positive supply (V⁻ = GND, V⁺ = V_S) the Input Common mode voltage, $V_{CM_ATT} = (+V_{IN} + (-V_{IN}))/2$ for the Attenuation inputs and $V_{CM_AMP} = (+I_{IN} + (-I_{IN}))/2$ for the Amplification inputs, has to stay between the MIN and MAX values determined by these formulas:

$$CM_{MAX} = V_S + 1/K_V * (V_S - V_{OCM})$$

$$CM_{MIN} = -1/K_V * V_{OCM}$$

K_V is a function of the Gain according to the table below:

Gain	0.096 V/V	0.192 V/V	0.384 V/V	0.768 V/V	1 V/V	2 V/V
K _V	0.12	0.218	0.414	0.806	1.065	2.096

Regardless to the values derived by the formula, the voltage on each input pin must never exceed the specified Absolute Maximum Ratings.

Below are some typical values:

Differential Input, Differential Output, V_S = 5V, V_{OCM} = 2.5V

Gain	V _{CM_ATT}		V _{CM_AMP}	
	Min	Max	Min	Max
0.096 V/V	-15 V*	+15 V*		
0.192 V/V	-11.5 V	+15 V		
0.384 V/V	-6 V	+11 V		
0.768 V/V	-3.1 V	+8.1 V		
1 V/V			-2.3 V	+7.3 V
2 V/V			-1.2 V	+6.2 V

* Limited by the operating ratings on input pins

In the case of a single ended input referred to ground (-V_{IN} = GND, -IN = GND) the table below summarizes the voltage range allowed on the +V_{IN} and +I_{IN} inputs.

Single Ended Input, Differential Output, V_S = 5V, V_{OCM} = 2.5V, -V_{IN} = GND, -I_{IN} = GND

Gain	+V _{IN}		+IN	
	Min	Max	Min	Max
0.096 V/V	-15 V*	+15 V*		
0.192 V/V	-15 V*	+15 V*		
0.384 V/V	-12 V**	+12 V**		
0.768 V/V	-6 V**	+6 V**		
1 V/V			-4.6 V**	+4.6 V**
2 V/V			-2.3 V**	+2.3 V**

* Limited by the operating ratings on input pins

** Limited by the output voltage swing (0.2V to V_S-0.2V on both +V_{OUT} and -V_{OUT})

Single Ended Output

In this mode the LMP7312 behaves as a Difference Amplifier, with -V_{OUT}/V_R being the reference output voltage when a zero volt differential input signal is applied. The voltages at the OpAmp inputs are determined by +V_{IN} and -V_{OUT}/V_R voltages. The voltage range of +V_{IN} and +I_{IN} inputs is as follows:

$$V_{MAX} = V_S + 1/K_V * (V_S - (-V_{OUT}/V_R))$$

$$V_{MIN} = -1/K_V * (-V_{OUT}/V_R)$$

Regardless of the values derived by the formula, the voltage on each input pin must never exceed the specified Absolute Maximum Ratings.

Below are some typical values:

Differential Input, Single Ended Output, V_S = 5V, V_{OCM} = GND, and -V_{OUT}/V_R = 2.5V

Gain	+V _{IN}		+I _{IN}	
	Min	Max	Min	Max
0.096 V/V	-15 V*	+15 V*		
0.192 V/V	-11.5 V*	+15 V		
0.384 V/V	-6 V	+11 V		
0.768 V/V	-3.1 V	+8.1 V		
1 V/V			-2.3 V	+7.3 V
2 V/V			-1.2 V	+6.2 V

* Limited by the operating ratings on input pins

In the case of a single ended input referred to ground (-V_{IN} = GND, -IN = GND) this table summarize the voltage ranges allowed on the +V_{IN} and +I_{IN} inputs.

Single Ended Input, Single Ended Output, V_S = 5V, V_{OCM} = GND, -V_{OUT}/V_R = 2.5V, -V_{IN} = GND, -I_{IN} = GND

Gain	+V _{IN}		+I _{IN}	
	Min	Max	Min	Max
0.096 V/V	-15 V*	+15 V*		
0.192 V/V	-11.5 V	+12 V**		
0.384 V/V	-6 V**	+6 V**		
0.768 V/V	-3 V**	+3 V**		
1 V/V			-2.3 V**	+2.3 V**
2 V/V			-1.1 V**	+1.1 V**

* Limited by the operating ratings on input pins

** Limited by the output voltage swing (0.2V to V_S-0.2V on +V_{OUT})

SERIAL INTERFACE CONTROL OPERATION

The serial interface control of the LMP7312 can be supplied with a voltage between 2.7V and 5.5V through the V_{IO} pin for compatibility with different logic families present in the market. The LMP7312 Attenuation, Amplification, Null switch and HiZ modes are controlled by a register. Data to be written into the control register is first loaded into the LMP7312 via the serial interface. The serial interface employs a 5-bit shift register. Data is loaded through the serial data input, SDI. Data passing through the shift register is obtained through the serial data output, SDO. The serial clock, SCK controls the serial loading process. All five data bits are required to correctly program the device. The falling edge of CS enables the shift register to receive data. The SCK signal must be high during the falling edge of CS. Each data bit is clocked into the shift register on the rising edge of SCK. Data is transferred from the shift register to the holding register on the rising edge of CS. Operation is shown in the timing diagram .

SPI Registers

MSB				LSB
Gain_1	Gain_0	EN_CL	Null_SW	Hi_Z

Gain_0, Gain_1 bit: Gain Values

Different gains are available in Attenuation Mode or Amplification Mode according to the following Gain Table.

Gain_1	Gain_0	EN_CL	Gain Value (V/V)
0	0	0	0.096
0	1	0	0.192
1	0	0	0.384
1	1	0	0.768
1	0	1	1
1	1	1	2

EN_CL bit: Enable Amplification Mode

This register selects which input pair is processed.

EN_CL	Mode	Description
0	Attenuation Mode	$\pm V_{IN}$ inputs are processed through the 104.16k input resistors
1	Amplification Mode	$\pm IN$ inputs are processed through the 40k input resistors

NULL_SW bit: Input Offset Nulling Switch Mode

This register selects a mode in which the amplifier is not processing any input but it is configured in unity gain to allow system level amplifier offset calibration. The Nulling Switch mode is available in both single ended and fully differential output mode. The LMP7312 in Nulling Switch and fully differential mode has the following configuration.

NULL_SW	Mode	Description
0	Normal Operation Mode	$\pm V_{IN}$ and $\pm IN$ inputs are processed depending on EN_CL register setting.
1	Nulling Switch Mode	Enables to evaluate the offset of the internal amplifier for system level calibration

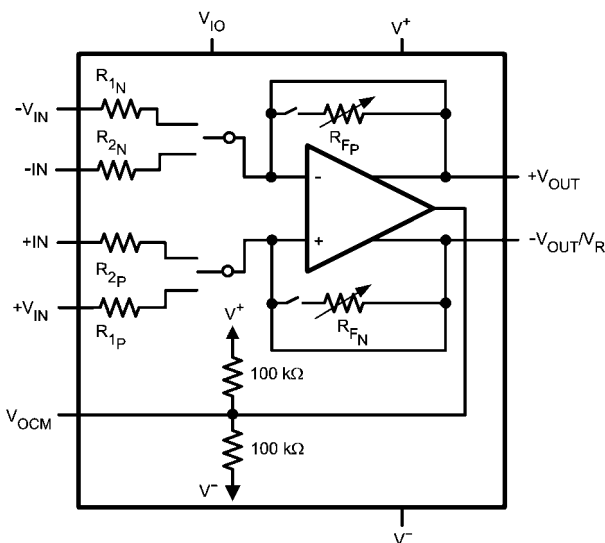

FIGURE 4. LMP7312 in Nulling Switch Mode

In this condition at the Output pins is possible to measure the input voltage offset of the op-amp:

Output Mode	+V _{OUT}	-V _{OUT} /V _R
Differential	$V_{CM_out} + V_{OS}/2$	$V_{CM_out} - V_{OS}/2$
Single-Ended	$V_R + V_{OS}$	V_R

Hi_Z bit: High Impedance

In this mode both outputs +V_{OUT} and -V_{OUT}/V_R of the LMP7312 are in tri-state [Figure 5](#).

Hi_Z	Mode	Description
0	Normal Operation Mode	The LMP7312 is configured according to value of the other 4 bits of the register.
1	High Impedance Mode	The LMP7312 output is in high impedance

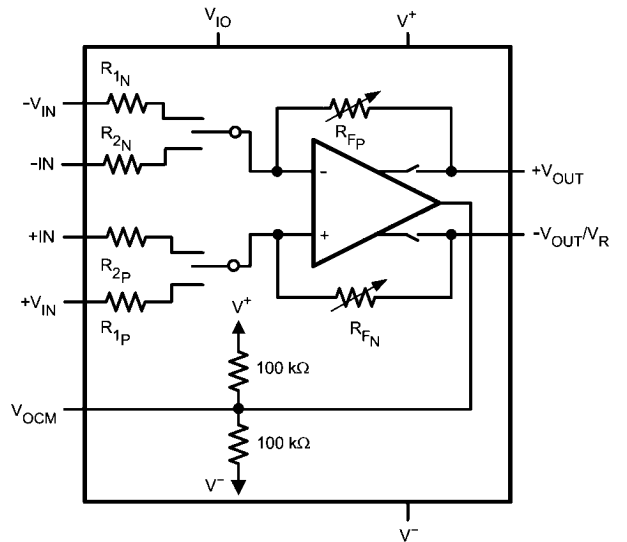

FIGURE 5. LMP7312 in High Impedance Mode

30075560

30075507

In each case the SPI registers require 5 bits. The table below is a summary of all allowed configurations.

MSB					LSB		
Gain_1	Gain_0	EN_CL	Null_SW	Hi_Z	Gain Value (V/V)	Mode of Operation	
0	0	0	0	0	0.096	Attenuation Mode	
0	1	0	0	0	0.192	Attenuation Mode	
1	0	0	0	0	0.384	Attenuation Mode	
1	1	0	0	0	0.768	Attenuation Mode	
1	0	1	0	0	1	Amplification Mode	
1	1	1	0	0	2	Amplification Mode	
x	x	x	x	1	–	High Impedance Output	
x	x	x	1	0	1	Null Switch Mode	

Daisy Chain

The LMP7312 supports daisy chaining of the serial data stream between multiple chips. To use this feature serial data is clocked into the first chip SDI pin, and the next chip SDI pin is connected to the SDO pin of the first chip. Both chips may share a chip select signal, or the second chip can be enabled

separately. When the chip select pin goes low on both chips and 5 bits have been clocked into the first chip the next 5 clock cycle begins moving new configuration data into the second chip. With a full 10 clock cycles both chips have valid data and the chip select pin of both chips should be brought high to prevent the data from overshooting.

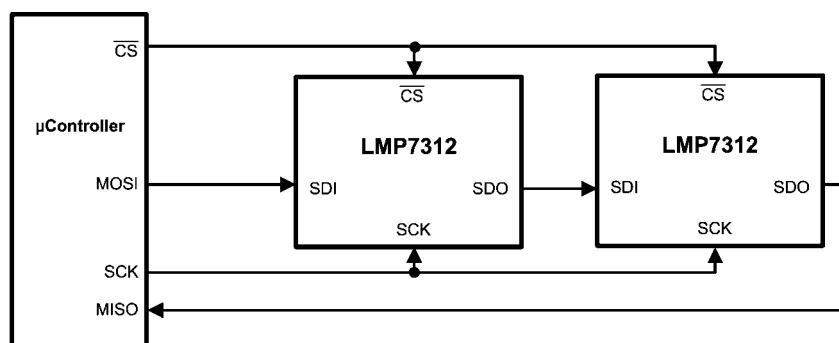

30075511

FIGURE 6. Daisy chain

Shared 4-wire SPI with ADC

The LMP7312 is a good choice when interfacing to differential analog to digital converters ADC141S626 and ADC161S626 of PowerWise® Family. Its SPI interface has been designed to enable sharing CSB with the ADC. LMP7312 register access happens only when CSB is asserted low while SCK is high. However, the ADC starts conversion under any of the following conditions: (1) CSB goes low while SCK is high, (2)

CSB goes low while SCK is low, (3) CSB and SCK both going low. Therefore, if a system uses timing condition #2 above, LMP7312 and ADC1x1S626 can share CSB and SCK as shown in Figure 7. The only side-effect would be that writing to LMP7312 triggers an ADC conversion, but then the result can be ignored. At other times, the LMP7312 is not affected by the CSB assertions used to initiate normal ADC conversions.

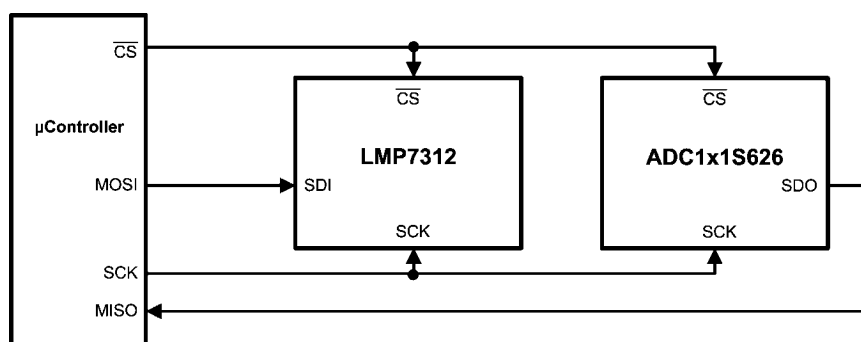

30075512

FIGURE 7. 4-wire SPI with ADC interface

LMP7312 IN 4-20mA CURRENT LOOP APPLICATION

The 4-20mA current loop shown in *Figure 8* is a common method of transmitting sensor information in many industrial process-monitoring applications. Transmitting sensor information via a current loop is particularly useful when the information has to be sent to a remote location over long distances (1000 feet, or more). The loop's operation is straightforward: a sensor's output voltage is first converted to a proportional current, with 4mA normally representing the sensor's zero-level output, and 20mA representing the sensor's full-scale output. Then, a receiver at the remote end converts the 4-20mA current back into a voltage which in turn can be further processed by a computer or display module. A typical 4-20mA current-loop circuit is made up of four individual elements: a sensor/transducer; a voltage-to-current converter (commonly referred to as a transmitter and/or signal conditioner); a loop power supply; and a receiver/monitor. In loop powered applications, all four elements are connected in a closed, series circuit, loop configuration (*Figure 8*). Sensors provide an output voltage whose value represents the physical parameter being measured. The transmitter amplifies and conditions the sensor's output, and then converts this voltage to a proportional 4-20mA dc-current that circulates within the closed series-loop. The loop power-supply generally provides all operating power to the transmitter and receiver, and any other

loop components that require a well-regulated dc voltage. In loop-powered applications, the power supply's internal elements also furnish a path for closing the series loop. The receiver/monitor, normally a subsection of a panel meter or data acquisition system, converts the 4-20mA current back into a voltage which can be further processed and/or displayed. The high DC performance of the LMP7312 makes this difference amplifier an ideal choice for use in current loop AFE receiver. The LMP7312 has a low input offset voltage and low input offset voltage drift when configured in amplification mode. In the circuit shown in *Figure 8* the LMP7312 is in amplification mode with a gain of 2V/V and differential output in order to well match the input stage of the ADC141S626 (SAR ADC with differential input). The shunt resistor is 100ohm in order to have a max voltage drop of 2V when 20mA flows in the loop. The first order filter between the LMP7312 and the ADC141S626 reduces the noise bandwidth and allows handling input signal up to 2kHz. That frequency has been calculated taking in account the roll off of the filter and ensuring a gain error less than 1LSB of the ADC141S626. In order to utilize the maximum number of bits of the ADC141S626 in this configuration, a 4.1V reference voltage is used. With this system, the current of the 4-20mA loop is accurately gained to the full scale of the ADC and then digitized for further processing.

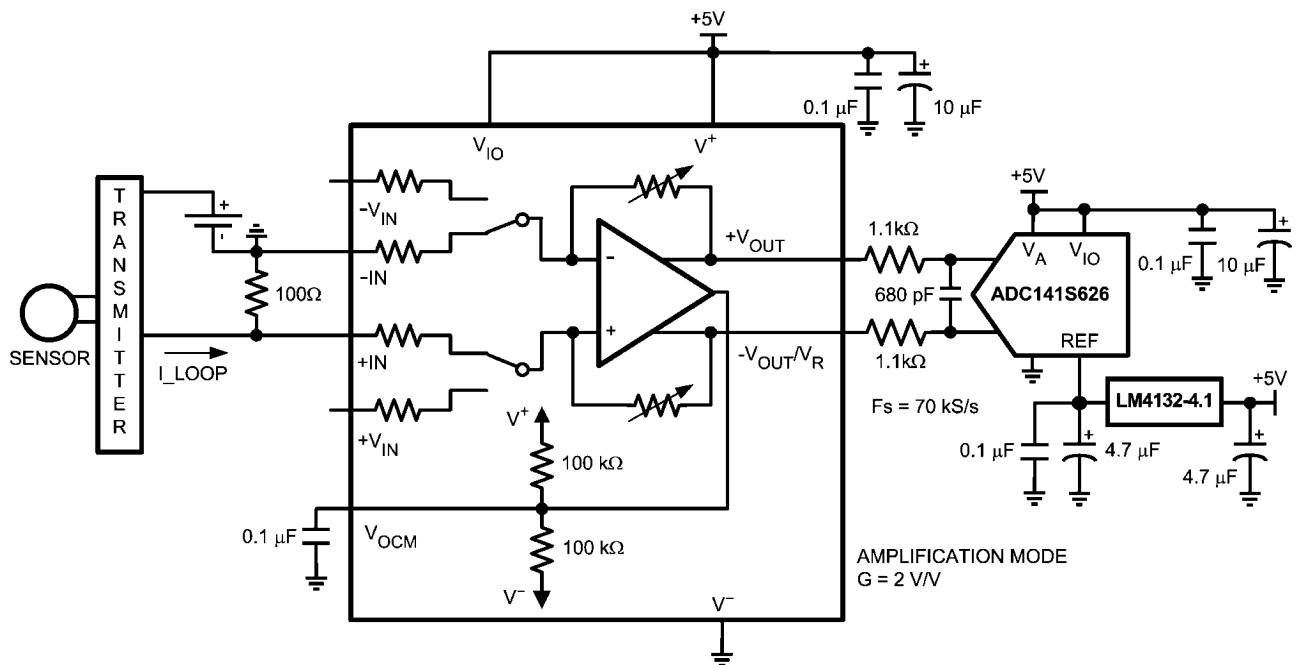

FIGURE 8. LMP7312 in 4-20mA Current Loop application

LAYOUT CONSIDERATIONS

Power supply bypassing

In order to preserve the gain accuracy of the LMP7312, power supply stability requires particular attention. The LMP7312 guarantees minimum PSRR of 90dB (or 31.62 $\mu\text{V/V}$). However, the dynamic range, the gain accuracy and the inherent low-noise of the amplifier can be compromised by introducing and amplifying power supply noise. To decouple the LMP7312 from supply line AC noise, a 0.1 μF ceramic capacitor should be located on the supply line, close to the

LMP7312. Adding a 10 μF tantalum capacitor in parallel with the 0.1 μF ceramic capacitor will reduce the noise introduced to the LMP7312 even further by providing an AC path to ground for most frequency ranges.

APPENDIX

Offset Voltage and Offset Voltage Drift calculation

Listed in the table below are the calculated values for Offset Voltage and Offset Voltage Drift based on the max specifications of these parameters for the core op-amp (for all gain configurations).

30075561

Parameter	Unit	Value					
Gain	V/V	0.096	0.192	0.384	0.768	1	2
Total Offset Input Referred (MAX)	μV	± 1141	± 620	± 360	± 230	± 200	± 150
Total Offset Output Referred (MAX)	μV	± 109	± 119	± 138	± 176	± 200	± 300
TCV _{OS} Input Referred @ 25°C (MAX)	$\mu\text{V}/^\circ\text{C}$	± 32.3	± 18.6	± 10.8	± 6.9	± 6	± 4.5
TCV _{OS} Output Referred @ 25°C (MAX)	$\mu\text{V}/^\circ\text{C}$	± 3.3	± 3.6	± 4.1	± 5.3	± 6	± 9

Noise calculation

Listed in the table below are the calculated values for Voltage Noise based on the spectral density of the core op-amp at 10kHz (for all gain configurations).

Parameter	Unit	Value					
Gain	V/V	0.096	0.192	0.384	0.768	1	2
Total Noise Referred to Input	$\text{nV}/\sqrt{\text{Hz}}$	211	150	112	89	53	46
Total Noise Referred to Output	$\text{nV}/\sqrt{\text{Hz}}$	20	29	43	68	53	92

Input resistance calculation

The common mode input resistance is the resistance seen from node "A" when $\Delta V_1 = \Delta V_2 = 0$ and a common mode voltage ΔV_{CM} is applied to both inputs of the LMP7312. The

differential input resistance is the resistance seen from the nodes "B" and "C" when $\Delta V_{CM}=0$ and a differential voltage $\Delta V_1 = \Delta V_2 = V/2$ is applied to the inputs of the LMP7312.

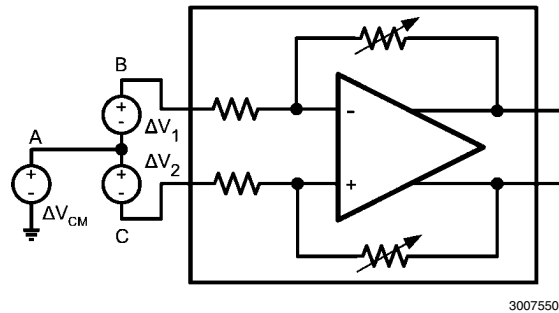
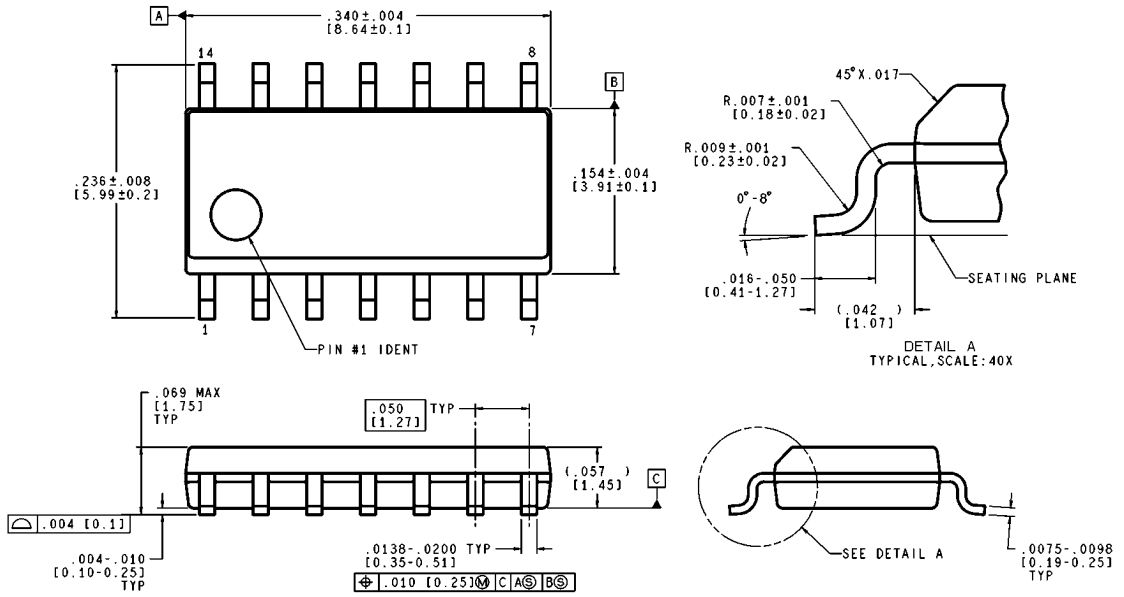

FIGURE 9. Circuit for Input Resistance calculation

Mode of Operation		Unit	Gains			
Attenuation Mode			0.096	0.192	0.384	0.768
	Common Mode Resistance	$\text{k}\Omega$	57.08	62.08	72.08	92.08
	Differential Resistance	$\text{k}\Omega$	228.30	248.30	288.30	368.30
Amplification Mode			1		2	
	Common Mode Resistance	$\text{k}\Omega$	40.0		60.0	
	Differential Resistance	$\text{k}\Omega$	160.0		240.0	

Physical Dimensions inches (millimeters) unless otherwise noted



CONTROLLING DIMENSION IS INCH
VALUES IN [] ARE MILLIMETERS

M14A (Rev J)

**14-Pin SOIC
NS Package Number M14A**

Notes

LMP7312

Notes

For more National Semiconductor product information and proven design tools, visit the following Web sites at:
www.national.com

Products		Design Support	
Amplifiers	www.national.com/amplifiers	WEBENCH® Tools	www.national.com/webench
Audio	www.national.com/audio	App Notes	www.national.com/appnotes
Clock and Timing	www.national.com/timing	Reference Designs	www.national.com/refdesigns
Data Converters	www.national.com/adc	Samples	www.national.com/samples
Interface	www.national.com/interface	Eval Boards	www.national.com/evalboards
LVDS	www.national.com/lvds	Packaging	www.national.com/packaging
Power Management	www.national.com/power	Green Compliance	www.national.com/quality/green
Switching Regulators	www.national.com/switchers	Distributors	www.national.com/contacts
LDOs	www.national.com/ldo	Quality and Reliability	www.national.com/quality
LED Lighting	www.national.com/led	Feedback/Support	www.national.com/feedback
Voltage References	www.national.com/vref	Design Made Easy	www.national.com/easy
PowerWise® Solutions	www.national.com/powerwise	Applications & Markets	www.national.com/solutions
Serial Digital Interface (SDI)	www.national.com/sdi	Mil/Aero	www.national.com/milaero
Temperature Sensors	www.national.com/tempensors	SolarMagic™	www.national.com/solarmagic
PLL/VCO	www.national.com/wireless	PowerWise® Design University	www.national.com/training

THE CONTENTS OF THIS DOCUMENT ARE PROVIDED IN CONNECTION WITH NATIONAL SEMICONDUCTOR CORPORATION ("NATIONAL") PRODUCTS. NATIONAL MAKES NO REPRESENTATIONS OR WARRANTIES WITH RESPECT TO THE ACCURACY OR COMPLETENESS OF THE CONTENTS OF THIS PUBLICATION AND RESERVES THE RIGHT TO MAKE CHANGES TO SPECIFICATIONS AND PRODUCT DESCRIPTIONS AT ANY TIME WITHOUT NOTICE. NO LICENSE, WHETHER EXPRESS, IMPLIED, ARISING BY ESTOPPEL OR OTHERWISE, TO ANY INTELLECTUAL PROPERTY RIGHTS IS GRANTED BY THIS DOCUMENT.

TESTING AND OTHER QUALITY CONTROLS ARE USED TO THE EXTENT NATIONAL DEEMS NECESSARY TO SUPPORT NATIONAL'S PRODUCT WARRANTY. EXCEPT WHERE MANDATED BY GOVERNMENT REQUIREMENTS, TESTING OF ALL PARAMETERS OF EACH PRODUCT IS NOT NECESSARILY PERFORMED. NATIONAL ASSUMES NO LIABILITY FOR APPLICATIONS ASSISTANCE OR BUYER PRODUCT DESIGN. BUYERS ARE RESPONSIBLE FOR THEIR PRODUCTS AND APPLICATIONS USING NATIONAL COMPONENTS. PRIOR TO USING OR DISTRIBUTING ANY PRODUCTS THAT INCLUDE NATIONAL COMPONENTS, BUYERS SHOULD PROVIDE ADEQUATE DESIGN, TESTING AND OPERATING SAFEGUARDS.

EXCEPT AS PROVIDED IN NATIONAL'S TERMS AND CONDITIONS OF SALE FOR SUCH PRODUCTS, NATIONAL ASSUMES NO LIABILITY WHATSOEVER, AND NATIONAL DISCLAIMS ANY EXPRESS OR IMPLIED WARRANTY RELATING TO THE SALE AND/OR USE OF NATIONAL PRODUCTS INCLUDING LIABILITY OR WARRANTIES RELATING TO FITNESS FOR A PARTICULAR PURPOSE, MERCHANTABILITY, OR INFRINGEMENT OF ANY PATENT, COPYRIGHT OR OTHER INTELLECTUAL PROPERTY RIGHT.

LIFE SUPPORT POLICY

NATIONAL'S PRODUCTS ARE NOT AUTHORIZED FOR USE AS CRITICAL COMPONENTS IN LIFE SUPPORT DEVICES OR SYSTEMS WITHOUT THE EXPRESS PRIOR WRITTEN APPROVAL OF THE CHIEF EXECUTIVE OFFICER AND GENERAL COUNSEL OF NATIONAL SEMICONDUCTOR CORPORATION. As used herein:

Life support devices or systems are devices which (a) are intended for surgical implant into the body, or (b) support or sustain life and whose failure to perform when properly used in accordance with instructions for use provided in the labeling can be reasonably expected to result in a significant injury to the user. A critical component is any component in a life support device or system whose failure to perform can be reasonably expected to cause the failure of the life support device or system or to affect its safety or effectiveness.

National Semiconductor and the National Semiconductor logo are registered trademarks of National Semiconductor Corporation. All other brand or product names may be trademarks or registered trademarks of their respective holders.

Copyright© 2010 National Semiconductor Corporation

For the most current product information visit us at www.national.com



National Semiconductor Americas Technical Support Center
 Email: support@nsc.com
 Tel: 1-800-272-9959

National Semiconductor Europe Technical Support Center
 Email: europe.support@nsc.com

National Semiconductor Asia Pacific Technical Support Center
 Email: ap.support@nsc.com

National Semiconductor Japan Technical Support Center
 Email: jpn.feedback@nsc.com

IMPORTANT NOTICE

Texas Instruments Incorporated and its subsidiaries (TI) reserve the right to make corrections, modifications, enhancements, improvements, and other changes to its products and services at any time and to discontinue any product or service without notice. Customers should obtain the latest relevant information before placing orders and should verify that such information is current and complete. All products are sold subject to TI's terms and conditions of sale supplied at the time of order acknowledgment.

TI warrants performance of its hardware products to the specifications applicable at the time of sale in accordance with TI's standard warranty. Testing and other quality control techniques are used to the extent TI deems necessary to support this warranty. Except where mandated by government requirements, testing of all parameters of each product is not necessarily performed.

TI assumes no liability for applications assistance or customer product design. Customers are responsible for their products and applications using TI components. To minimize the risks associated with customer products and applications, customers should provide adequate design and operating safeguards.

TI does not warrant or represent that any license, either express or implied, is granted under any TI patent right, copyright, mask work right, or other TI intellectual property right relating to any combination, machine, or process in which TI products or services are used. Information published by TI regarding third-party products or services does not constitute a license from TI to use such products or services or a warranty or endorsement thereof. Use of such information may require a license from a third party under the patents or other intellectual property of the third party, or a license from TI under the patents or other intellectual property of TI.

Reproduction of TI information in TI data books or data sheets is permissible only if reproduction is without alteration and is accompanied by all associated warranties, conditions, limitations, and notices. Reproduction of this information with alteration is an unfair and deceptive business practice. TI is not responsible or liable for such altered documentation. Information of third parties may be subject to additional restrictions.

Resale of TI products or services with statements different from or beyond the parameters stated by TI for that product or service voids all express and any implied warranties for the associated TI product or service and is an unfair and deceptive business practice. TI is not responsible or liable for any such statements.

TI products are not authorized for use in safety-critical applications (such as life support) where a failure of the TI product would reasonably be expected to cause severe personal injury or death, unless officers of the parties have executed an agreement specifically governing such use. Buyers represent that they have all necessary expertise in the safety and regulatory ramifications of their applications, and acknowledge and agree that they are solely responsible for all legal, regulatory and safety-related requirements concerning their products and any use of TI products in such safety-critical applications, notwithstanding any applications-related information or support that may be provided by TI. Further, Buyers must fully indemnify TI and its representatives against any damages arising out of the use of TI products in such safety-critical applications.

TI products are neither designed nor intended for use in military/aerospace applications or environments unless the TI products are specifically designated by TI as military-grade or "enhanced plastic." Only products designated by TI as military-grade meet military specifications. Buyers acknowledge and agree that any such use of TI products which TI has not designated as military-grade is solely at the Buyer's risk, and that they are solely responsible for compliance with all legal and regulatory requirements in connection with such use.

TI products are neither designed nor intended for use in automotive applications or environments unless the specific TI products are designated by TI as compliant with ISO/TS 16949 requirements. Buyers acknowledge and agree that, if they use any non-designated products in automotive applications, TI will not be responsible for any failure to meet such requirements.

Following are URLs where you can obtain information on other Texas Instruments products and application solutions:

Products

Audio	www.ti.com/audio
Amplifiers	amplifier.ti.com
Data Converters	dataconverter.ti.com
DLP® Products	www.dlp.com
DSP	dsp.ti.com
Clocks and Timers	www.ti.com/clocks
Interface	interface.ti.com
Logic	logic.ti.com
Power Mgmt	power.ti.com
Microcontrollers	microcontroller.ti.com
RFID	www.ti-rfid.com
OMAP Mobile Processors	www.ti.com/omap
Wireless Connectivity	www.ti.com/wirelessconnectivity

Applications

Communications and Telecom	www.ti.com/communications
Computers and Peripherals	www.ti.com/computers
Consumer Electronics	www.ti.com/consumer-apps
Energy and Lighting	www.ti.com/energy
Industrial	www.ti.com/industrial
Medical	www.ti.com/medical
Security	www.ti.com/security
Space, Avionics and Defense	www.ti.com/space-avionics-defense
Transportation and Automotive	www.ti.com/automotive
Video and Imaging	www.ti.com/video

TI E2E Community Home Page

e2e.ti.com

Mailing Address: Texas Instruments, Post Office Box 655303, Dallas, Texas 75265
Copyright © 2011, Texas Instruments Incorporated