

BZX85C 3V3 - 33 Series 1.3 Watt Zeners

Absolute Maximum Ratings*

TA = 25°C unless otherwise noted

Symbol	Parameter	Value	Units
T _{STG}	Storage Temperature Range	-65 to +200	°C
T _J	Maximum Junction Operating Temperature	+ 200	°C
	Lead Temperature (1/16" from case for 10 seconds)	+ 230	°C
P _D	Total Device Dissipation	1.3	W
	Derate above 25°C	10.4	mW/°C

Tolerance: C = 5%

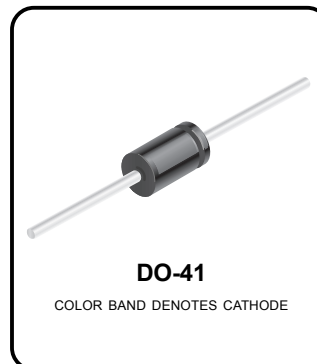

*These ratings are limiting values above which the serviceability of the diode may be impaired.

NOTES:

- 1) These ratings are based on a maximum junction temperature of 200 degrees C.
- 2) These are steady state limits. The factory should be consulted on applications involving pulsed or low duty cycle operations.

Electrical Characteristics

TA = 25°C unless otherwise noted

Device	V _Z (V)	Z _Z (Ω)	@ I _{ZT} (mA)	Z _{ZK} (Ω)	@ I _{ZK} (mA)	V _R (V)	@ I _R (μA)	I _{SRG} (mA)	I _{ZRM} (mA)
BZX85C 3V3	3.3	20	80	400	1.0	1.0	60	1,380	276
BZX85C 3V6	3.6	15	60	500	1.0	1.0	30	1,260	252
BZX85C 3V9	3.9	15	60	500	1.0	1.0	5.0	1,190	234
BZX85C 4V3	4.3	13	50	500	1.0	1.0	3.0	1,070	217
BZX85C 4V7	4.7	13	45	600	1.0	1.5	3.0	970	193
BZX85C 5V1	5.1	10	45	500	1.0	2.0	1.0	890	178
BZX85C 5V6	5.6	7.0	45	400	1.0	2.0	1.0	810	162
BZX85C 6V2	6.2	4.0	35	300	1.0	3.0	1.0	730	146
BZX85C 6V8	6.8	3.5	35	300	1.0	4.0	1.0	660	133
BZX85C 7V5	7.5	3.0	35	200	1.0	4.5	1.0	605	121
BZX85C 8V2	8.2	5.0	25	200	0.5	5.0	1.0	550	110
BZX85C 9V1	9.1	5.0	25	200	0.5	6.5	1.0	500	100
BZX85C 10	10	7.0	25	200	0.5	7.0	0.5	454	91
BZX85C 11	11	8.0	20	300	0.5	7.7	0.5	414	83
BZX85C 12	12	9.0	20	350	0.5	8.4	0.5	380	76
BZX85C 13	13	10	20	400	0.5	9.1	0.5	344	69
BZX85C 15	15	15	15	500	0.5	10.5	0.5	304	61
BZX85C 16	16	15	15	500	0.5	11	0.5	285	57
BZX85C 18	18	20	15	500	0.5	12.5	0.5	250	50
BZX85C 20	20	24	10	600	0.5	14	0.5	225	45
BZX85C 22	22	25	10	600	0.5	15.5	0.5	205	41
BZX85C 24	24	25	10	600	0.5	17	0.5	190	38
BZX85C 27	27	30	8.0	750	0.25	19	0.5	170	34
BZX85C 30	30	30	8.0	1,000	0.25	21	0.5	150	30
BZX85C 33	33	35	8.0	1,200	0.25	23	0.5	135	27

V_F Forward Voltage = 1.2 V Maximum @ I_F = 200 mA for all BZX85 series

Typical Characteristics

Zener Current vs. Zener Voltage

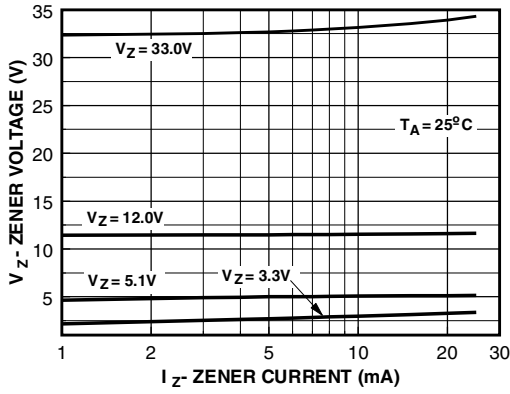

Zener Current vs. Zener Impedance

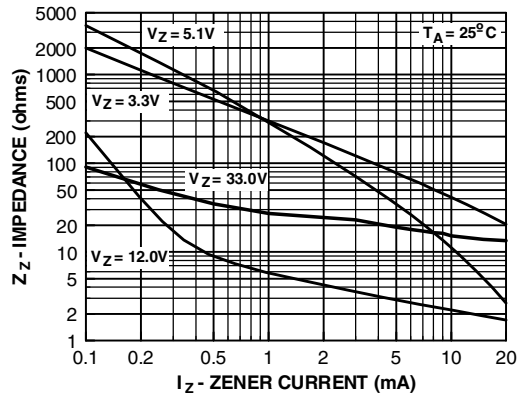

3.3 Zener Voltage vs. Temperature

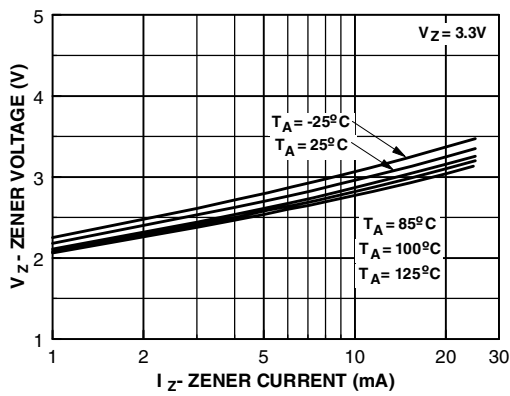

5.1 Zener Voltage vs. Temperature

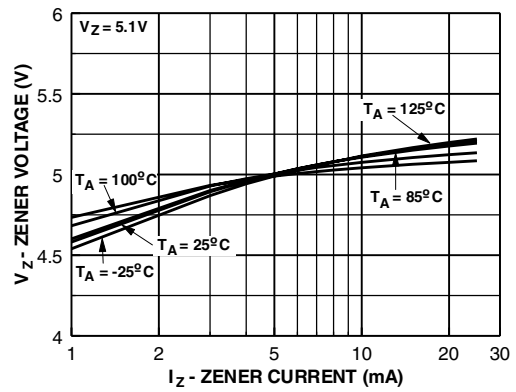

12 Zener Voltage vs. Zener Temperature

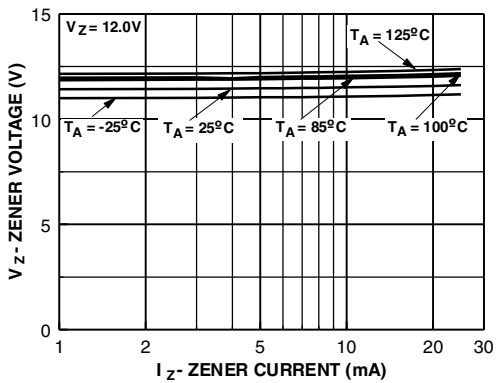

33 Zener Voltage vs. Zener Temperature

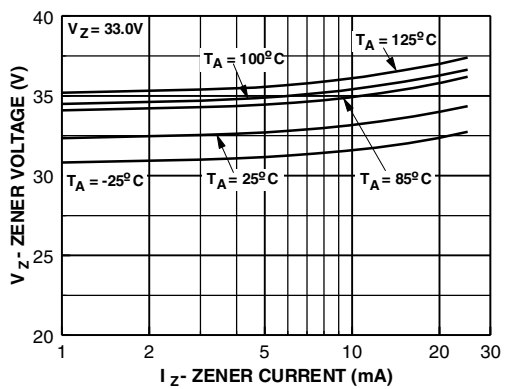

DO-41 (Glass) Tape and Ammo Data



DO-41 (Glass) Packaging Configuration: Figure 1.0

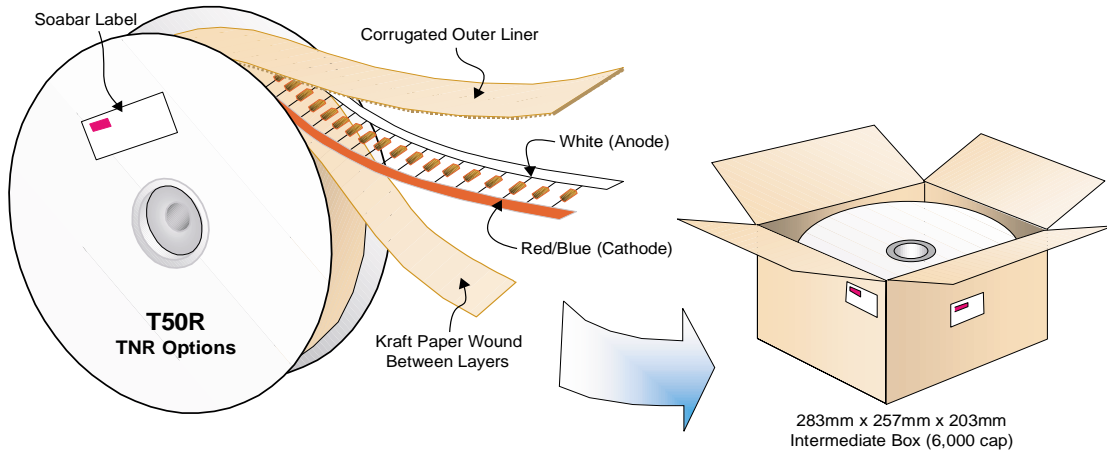

DO-41 (Glass) Packaging Information Table : Figure 2.0

DO-41 (Glass) Packaging Information			
Packaging Option	T50R	T50A	Standard (no flow code)
Packaging type	TNR	Ammo	Bag
Qty per Reel/Tube/Bag	3,000	3,000	250
Reel Size (inch diameter)	10.5	-	-
Inside Tape Spacing (mm)	52	52	-
Int Box Dimension (mm)	283x257x203	406x267x184	381x203x127
Max qty per Box	6,000	30,000	5,000
Weight per unit (gm)	0.320	0.320	0.320
Weight per Reel (kg)	1.356	1.077	-
Note/Comments			Bulk

Soabar Label sample

FAIRCHILD SEMICONDUCTOR™	P.O. No.	BLK-BRN
TYPE 1N4744A	MARK	
REV A2	PART No.	
PKG	EC No.	
QTY 3,000	M.O. No.	OX5046F035
Q.C.	DATE	D9903
MFD. UNDER US PAT 3,025,589 & OTHER US PATS & APPLICATIONS		

DO-41 (Glass) Bulk Packing Configuration: Figure 3.0

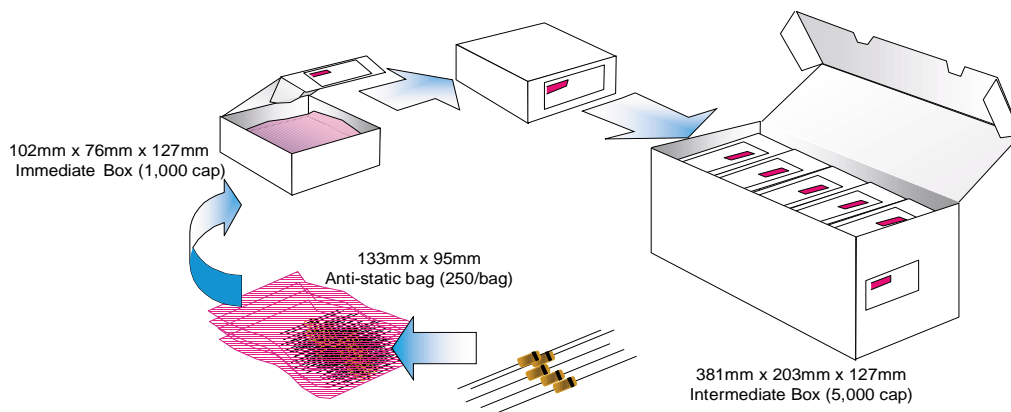

DO-41 (Glass) Tape and Ammo Data, continued

DO-41 (Glass) Ammo Packing Configuration: Figure 4.0

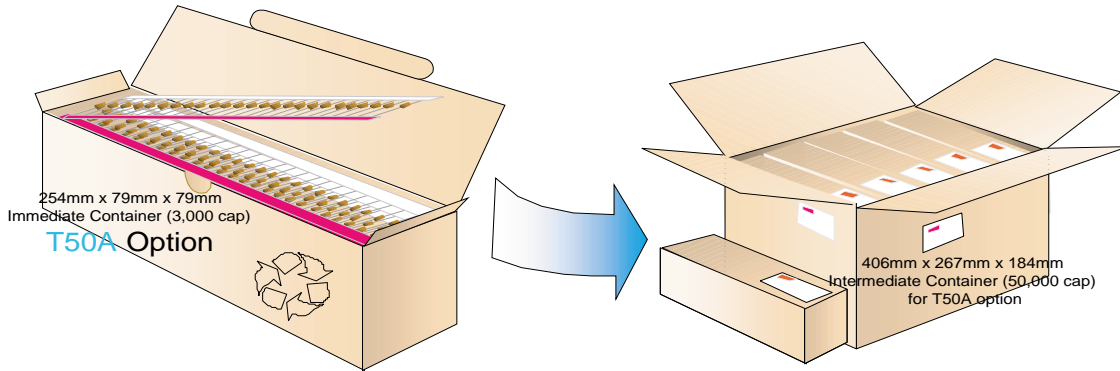

DO-41 (Glass) Taping Dimension: Figure 5.0

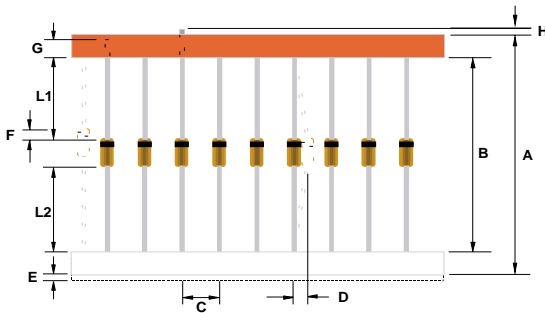

TAPING DIMENSIONS

	INCH	MM	MILS	NOTES
A	2.520 +0.066/ -0.027	64.00 +1.69/ -0.69	2519 +66.5/ -27.0	Overall width
B	2.047±0.027	52 ±0.69	2047±27	Inside Tape Spacing
C	0.200 ±0.0157	5.08 ±0.40	200 ±15.7	Component Pitch
D	0.047(max)	1.2(max)	47(max)	Component Misalignment
E	0.022(max)	0.55(max)	22(max)	Tape Mismatch
F	0.027(max)	±0.69	±27	Units in line w/ one another
G	0.126(min)	3.2(min)	126(min)	Lead amount between tapes
H	0	0	0	Lead amount beyond tapes
L1-L2	±0.027	±0.69	±27	Delta between two leads

DO-41 (Glass) Reel Dimension: Figure 6.0

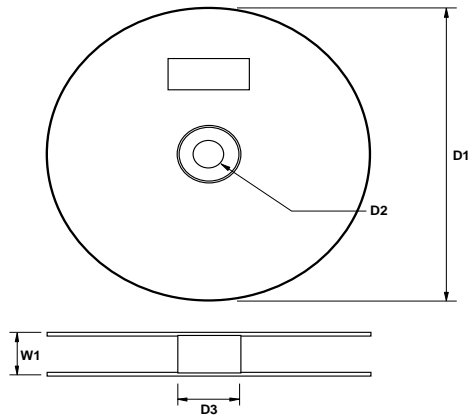

REEL DIMENSIONS

ITEM DESCRIPTION	SYMBOL	MINIMUM	MAXIMUM
Reel Diameter	D1	10.375	10.625
Arbor Hole Diameter (Standard)	D2	1.245	1.255
Core Diameter	D3	3.190	3.310
Flange to Flange Outer Width	W1		3.400

Note: All Dimensions are in inches

DO-41 (Glass) Package Dimensions



DO-41 (FS PKG Code D4)

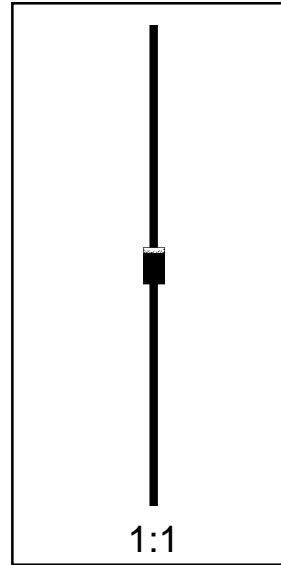
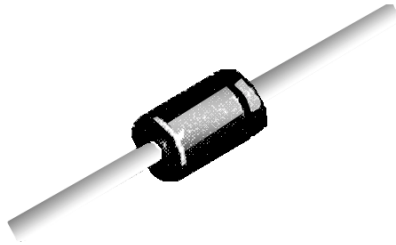

Scale 1:1 on letter size paper

Dimensions shown below are in:
inches [millimeters]

Part Weight per unit (gram): 0.32

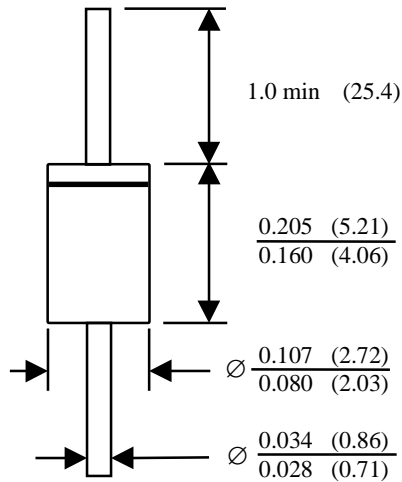

TRADEMARKS

The following are registered and unregistered trademarks Fairchild Semiconductor owns or is authorized to use and is not intended to be an exhaustive list of all such trademarks.

ACEx™	FASTr™	PowerTrench®	SyncFET™
Bottomless™	GlobalOptoisolator™	QFET™	TinyLogic™
CoolFET™	GTO™	QS™	UHC™
CROSSVOLT™	HiSeC™	QT Optoelectronics™	VCX™
DOME™	ISOPLANAR™	Quiet Series™	
E ² CMOS™	MICROWIRE™	SILENT SWITCHER®	
EnSigna™	OPTOLOGIC™	SMART START™	
FACT™	OPTOPLANAR™	SuperSOT™-3	
FACT Quiet Series™	PACMAN™	SuperSOT™-6	
FAST®	POP™	SuperSOT™-8	

DISCLAIMER

FAIRCHILD SEMICONDUCTOR RESERVES THE RIGHT TO MAKE CHANGES WITHOUT FURTHER NOTICE TO ANY PRODUCTS HEREIN TO IMPROVE RELIABILITY, FUNCTION OR DESIGN. FAIRCHILD DOES NOT ASSUME ANY LIABILITY ARISING OUT OF THE APPLICATION OR USE OF ANY PRODUCT OR CIRCUIT DESCRIBED HEREIN; NEITHER DOES IT CONVEY ANY LICENSE UNDER ITS PATENT RIGHTS, NOR THE RIGHTS OF OTHERS.

LIFE SUPPORT POLICY

FAIRCHILD'S PRODUCTS ARE NOT AUTHORIZED FOR USE AS CRITICAL COMPONENTS IN LIFE SUPPORT DEVICES OR SYSTEMS WITHOUT THE EXPRESS WRITTEN APPROVAL OF FAIRCHILD SEMICONDUCTOR CORPORATION. As used herein:

1. Life support devices or systems are devices or systems which, (a) are intended for surgical implant into the body, or (b) support or sustain life, or (c) whose failure to perform when properly used in accordance with instructions for use provided in the labeling, can be reasonably expected to result in significant injury to the user.
2. A critical component is any component of a life support device or system whose failure to perform can be reasonably expected to cause the failure of the life support device or system, or to affect its safety or effectiveness.

PRODUCT STATUS DEFINITIONS

Definition of Terms

Datasheet Identification	Product Status	Definition
Advance Information	Formative or In Design	This datasheet contains the design specifications for product development. Specifications may change in any manner without notice.
Preliminary	First Production	This datasheet contains preliminary data, and supplementary data will be published at a later date. Fairchild Semiconductor reserves the right to make changes at any time without notice in order to improve design.
No Identification Needed	Full Production	This datasheet contains final specifications. Fairchild Semiconductor reserves the right to make changes at any time without notice in order to improve design.
Obsolete	Not In Production	This datasheet contains specifications on a product that has been discontinued by Fairchild semiconductor. The datasheet is printed for reference information only.