

1.5SMCJ Series – 1500 Watt Surface Mount



1.5SMCJ Series Features

- RoHS Compliance designated by suffix “F”
- 1500 watt peak pulse power dissipation
- Available in voltages from 5.0V to 170V
- Unidirectional and bidirectional
- Glass passivated junction
- Low clamping factor
- Available in tape and reel (Reel quantity = 3,000 pieces)
- Each device 100% surge tested
- UL 497B Recognized, File # E135015
- Tape and Reel to EIA Standard RS-481-A

Absolute Maximum Ratings

Parameter	Value
Peak pulse power dissipation (PPPM) at 25°C	1500W
Operating and storage temperatures	-55°C to + 150°C

Mechanical Characteristics

- DO214AB package
- UL94V-0 Thermoset Epoxy
- Solder plated terminals
- Solderable per MIL-STD-750 Method 2026

Mechanical Dimensions

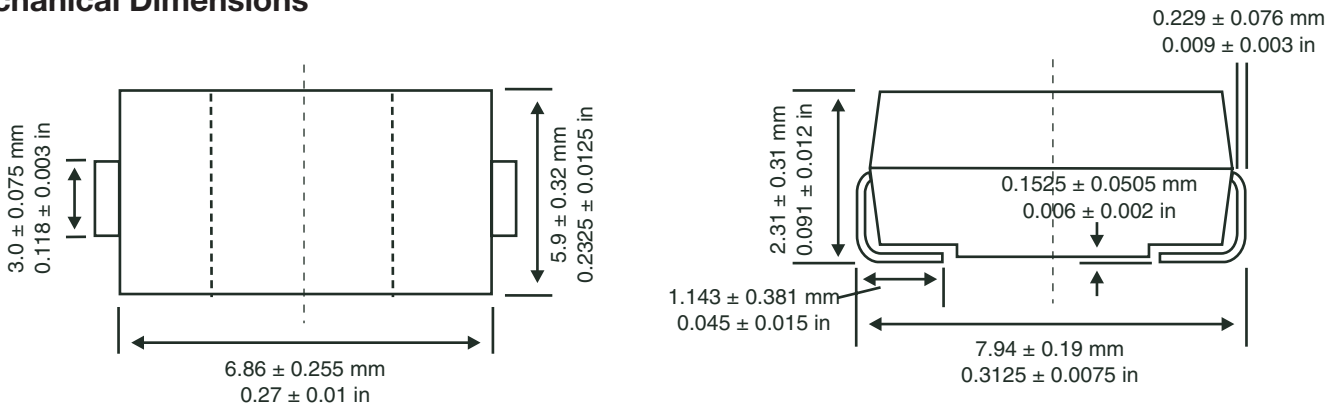

Standard Mounting Pad Layout

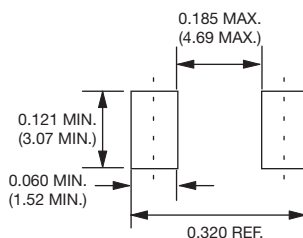

All dimensions in inches and (millimeters)

1.5SMCJ Series – 1500 Watt Surface Mount**Electrical Characteristics**

Part Number*	Uni Part Marking	Bi Part Marking	Rated Standoff Voltage V _{wm}	Breakdown Voltage			Maximum Stand By Current @V _{WM} + I _d	10/1000 μ s Maximum Clamping Voltage @I _{ppm} # V _c Max	10/1000 μ s Rated Peak Impulse Current I _{ppm} #
				V _{br} (Volts)		@I _t			
				(Volts)	Min	Max			
1.5SMCJ5.0	GDD	BDD	5	6.4	7.55	10	1000	9.6	156.2
1.5SMCJ5.0A	GDE	BDE	5	6.4	7.23	10	1000	9.2	163
1.5SMCJ6.0	GDF	BDF	6	6.67	8.45	10	1000	11.4	131.6
1.5SMCJ6.0A	GDG	BDG	6	6.67	7.67	10	1000	10.3	145.6
1.5SMCJ6.5	GDH	BDH	6.5	7.22	9.14	10	500	12.3	122
1.5SMCJ6.5A	GDK	BDK	6.5	7.22	8.3	10	500	11.2	133.9
1.5SMCJ7.0	GDL	BDL	7	7.78	9.86	10	200	13.3	112.8
1.5SMCJ7.0A	GDM	BDM	7	7.78	8.95	10	200	12	125
1.5SMCJ7.5	GDN	BDN	7.5	8.33	10.8	1	100	14.3	104.9
1.5SMCJ7.5A	GDP	BDP	7.5	8.33	9.58	1	100	12.9	116.3
1.5SMCJ8.0	GDQ	BDQ	8	8.89	11.3	1	50	15	100
1.5SMCJ8.0A	GDR	BDR	8	8.89	10.2	1	50	13.6	110.3
1.5SMCJ8.5	GDS	BDS	8.5	9.44	11.9	1	25	15.9	94.3
1.5SMCJ8.5A	GDT	BDT	8.5	9.44	10.8	1	20	14.4	104.2
1.5SMCJ9.0	GDU	BDU	9	10	12.8	1	10	16.9	88.7
1.5SMCJ9.0A	GDV	BDV	9	10	11.5	1	10	15.4	97.4
1.5SMCJ10	GDW	BDW	10	11.1	14.1	1	5	18.8	79.8
1.5SMCJ10A	GDX	BDX	10	11.1	12.8	1	5	17	88.2
1.5SMCJ11	GDY	BDY	11	12.2	15.4	1	5	20.1	74.6
1.5SMCJ11A	GDZ	BDZ	11	12.2	14.4	1	5	18.2	82.4
1.5SMCJ12	GED	BED	12	13.3	16.9	1	5	22	68.2
1.5SMCJ12A	GEE	BEE	12	13.3	15.3	1	5	19.9	75.3
1.5SMCJ13	GEF	BEF	13	14.4	18.2	1	5	23.8	63
1.5SMCJ13A	GEG	BEG	13	14.4	16.5	1	5	21.5	69.7
1.5SMCJ14	GEH	BEH	14	15.6	19.8	1	5	25.8	58.1
1.5SMCJ14A	GEK	BEK	14	15.6	17.9	1	5	23.2	64.7

* = Add "C" or "CA" suffix for bidirectional device types.

+ = For Bidirectional Types Having V_{WM} <= 10V, their I_D limit is doubled.

= See General Information for Impulse Current Waveform.

For Pb-Free add suffix - "F"

1.5SMCJ Series – 1500 Watt Surface Mount**Electrical Characteristics (continued)**

Part Number*	Uni Part Marking	Bi Part Marking	Rated Standoff Voltage V _{wm}	Breakdown Voltage			Maximum Stand By Current @V _{WM} + I _d	10/1000 μ s Maximum Clamping Voltage @I _{ppm} # V _c Max	10/1000 μ s Rated Peak Impulse Current I _{ppm} #
				V _{br} (Volts)		@I _t			
				(Volts)	Min	Max			
1.5SMCJ15	GEL	BEL	15	16.7	21.1	1	5	26.9	55.8
1.5SMCJ15A	GEM	BEM	15	16.7	19.2	1	5	24.4	61.5
1.5SMCJ16	GEN	BEN	16	17.8	22.6	1	5	28.8	52.1
1.5SMCJ16A	GEP	BEP	16	17.8	20.5	1	5	26	57.7
1.5SMCJ17	GEQ	BEQ	17	18.9	23.9	1	5	30.5	49.2
1.5SMCJ17A	GER	BER	17	18.9	21.7	1	5	27.6	53.3
1.5SMCJ18	GES	BES	18	20	25.3	1	5	32.2	46.6
1.5SMCJ18A	GET	BET	18	20	23.3	1	5	29.2	51.4
1.5SMCJ20	GEU	BEU	20	22.2	28.1	1	5	35.8	41.9
1.5SMCJ20A	GEV	BEV	20	22.2	25.5	1	5	32.4	46.3
1.5SMCJ22	GEW	BEW	22	24.4	30.9	1	5	39.4	38.1
1.5SMCJ22A	GEX	BEX	22	24.4	28	1	5	35.5	42.2
1.5SMCJ24	GEY	BEY	24	26.7	33.8	1	5	43	34.9
1.5SMCJ24A	GEZ	BEZ	24	26.7	30.7	1	5	38.9	38.6
1.5SMCJ26	GFD	BFD	26	28.9	36.8	1	5	46.6	32.2
1.5SMCJ26A	GFE	BFE	26	28.9	32.2	1	5	42.1	35.6
1.5SMCJ28	GFF	BFF	28	31.1	39.4	1	5	50	30
1.5SMCJ28A	GFG	BFG	28	31.1	35.8	1	5	45.4	33
1.5SMCJ30	GFH	BFH	30	33.3	42.4	1	5	53.5	28
1.5SMCJ30A	GFK	BFK	30	33.3	38.3	1	5	48.4	31
1.5SMCJ33	GFL	BFL	33	36.7	46.9	1	5	59	25.2
1.5SMCJ33A	GFM	BFM	33	36.7	42.2	1	5	53.3	28.1
1.5SMCJ36	GFN	BFN	36	40	50.7	1	5	64.3	23.3
1.5SMCJ36A	GFP	BFP	36	40	46	1	5	58.1	25.8
1.5SMCJ40	GFQ	BFQ	40	44.4	56.3	1	5	71.4	21
1.5SMCJ40A	GFR	BFR	40	44.4	51.1	1	5	64.5	23.2

* = Add "C" or "CA" suffix for bidirectional device types.

+ = For Bidirectional Types Having V_{WM} <= 10V, their I_D limit is doubled.

= See General Information for Impulse Current Waveform.

For Pb-Free add suffix - "F"

1.5SMCJ Series – 1500 Watt Surface Mount**Electrical Characteristics (continued)**

Part Number*	Uni Part Marking	Bi Part Marking	Rated Standoff Voltage Vwm	Breakdown Voltage			Maximum Stand By Current @VWM+ Id	10/1000µs Maximum Clamping Voltage @Ippm# Vc Max	10/1000µs Rated Peak Impulse Current Ippm#
				Vbr (Volts)		@It			
				(Volts)	Min	Max			
1.5SMCJ43	GFS	BFS	43	47.8	60.5	1	5	76.7	19.6
1.5SMCJ43A	GFT	BFT	43	47.8	54.9	1	5	69.4	21.6
1.5SMCJ45	GFU	BFU	45	50	63.3	1	5	80.3	18.7
1.5SMCJ45A	GFV	BFV	45	50	57.5	1	5	72.7	20.6
1.5SMCJ48	GFW	BFW	48	53.3	67.5	1	5	85.5	17.5
1.5SMCJ48A	GFX	BFX	48	53.3	61.3	1	5	77.4	19.4
1.5SMCJ51	GFY	BFY	51	56.7	71.8	1	5	91.1	18.5
1.5SMCJ51A	GFZ	BFZ	51	56.7	65.2	1	5	82.4	18.2
1.5SMCJ54	GGD	BGD	54	60	76	1	5	96.3	15.6
1.5SMCJ54A	GGE	BGE	54	60	69	1	5	87.1	17.2
1.5SMCJ58	GGF	BGF	58	64.4	81.6	1	5	103	14.6
1.5SMCJ58A	GGG	BGG	58	64.4	74.6	1	5	93.6	16
1.5SMCJ60	GGH	BGH	60	66.7	84.5	1	5	107	14
1.5SMCJ60A	GGK	BGK	60	66.7	76.7	1	5	96.8	15.5
1.5SMCJ64	GGL	BGL	64	71.1	90.1	1	5	114	13.2
1.5SMCJ64A	GGM	BGM	64	71.1	81.8	1	5	103	14.6
1.5SMCJ70	GGN	BGN	70	77.8	98.6	1	5	125	12
1.5SMCJ70A	GGP	BGP	70	77.8	89.5	1	5	113	13.3
1.5SMCJ75	GGQ	BGQ	75	83.3	106	1	5	134	11.2
1.5SMCJ75A	GGR	BGR	75	83.3	95.8	1	5	121	12.4
1.5SMCJ78	GGS	BGS	78	86.7	110	1	5	139	10.8
1.5SMCJ78A	GGT	BGT	78	86.7	99.7	1	5	126	11.4
1.5SMCJ85	GGU	BGU	85	94.4	119.2	1	5	151	9.9
1.5SMCJ85A	GGV	BGV	85	94.4	108.2	1	5	137	10.4
1.5SMCJ90	GGW	BGW	90	100	126.5	1	5	160	9.4
1.5SMCJ90A	GGX	BGX	90	100	115.5	1	5	146	10.3

* = Add "C" or "CA" suffix for bidirectional device types.

+ = For Bidirectional Types Having VWM <= 10V, their ID limit is doubled.

= See General Information for Impulse Current Waveform.

For Pb-Free add suffix - "F"

1.5SMCJ Series – 1500 Watt Surface Mount**Electrical Characteristics (continued)**

Part Number*	Uni Part Marking	Bi Part Marking	Rated Standoff Voltage Vwm	Breakdown Voltage			Maximum Stand By Current @VWM+ Id	10/1000µs Maximum Clamping Voltage @Ippm# Vc Max	10/1000µs Rated Peak Impulse Current Ippm#
				Vbr (Volts)		@It			
				(Volts)	Min	Max			
1.5SMCJ100	GGY	BGY	100	111	141	1	5	179	8.4
1.5SMCJ100A	GGZ	BGZ	100	111	128	1	5	162	9.3
1.5SMCJ110	GHD	BHD	110	122	154	1	5	196	7.7
1.5SMCJ110A	GHE	BHE	110	122	140	1	5	177	8.4
1.5SMCJ120	GHF	BHF	120	133	169	1	5	214	7
1.5SMCJ120A	GHG	BHG	120	133	153	1	5	193	7.9
1.5SMCJ130	GHH	BHH	130	144	182	1	5	231	6.5
1.5SMCJ130A	GHK	BHK	130	144	165	1	5	209	7.2
1.5SMCJ150	GHL	BHL	150	167	211.5	1	5	268	5.6
1.5SMCJ150A	GHM	BHM	150	167	192	1	5	243	6.2
1.5SMCJ160	GHN	BHN	160	178	226	1	5	287	5.2
1.5SMCJ160A	GHP	BHP	160	178	205	1	5	259	5.8
1.5SMCJ170	GHQ	BHQ	170	189	239.5	1	5	304	4.9
1.5SMCJ170A	GHR	BHR	170	189	217.5	1	5	275	5.5

* = Add "C" or "CA" suffix for bidirectional device types.

+ = For Bidirectional Types Having VWM <= 10V, their ID limit is doubled.

= See General Information for Impulse Current Waveform.

For Pb-Free add suffix – "F"