

## LOW POWER NPN SILICON TRANSISTOR

Qualified per MIL-PRF-19500/391

### DEVICES

**2N3019**      **2N3057A**      **2N3700**  
**2N3019S**                      **2N3700S**  
   **2N3700UB**

**LEVELS**  
**JAN**  
**JANTX**  
**JANTXV**  
**JANS**

### ABSOLUTE MAXIMUM RATINGS ( $T_C = +25^\circ\text{C}$ unless otherwise noted)

Parameters / Test Conditions	Symbol	Value	Unit
Collector-Emitter Voltage	$V_{CEO}$	80	Vdc
Collector-Base Voltage	$V_{CBO}$	140	Vdc
Emitter-Base Voltage	$V_{EBO}$	7.0	Vdc
Collector Current	$I_C$	1.0	Adc
Total Power Dissipation @ $T_A = +25^\circ\text{C}$ <sup>(1)</sup>	$P_T$	2N3019; 2N3019S 2N3057A	W
@ $T_C = +25^\circ\text{C}$ <sup>(2)</sup>		2N3700, 2N3700UB	W
		2N3019; 2N3019S 2N3057A 2N3700 2N3700UB	W
Operating & Storage Jct Temp Range	$T_J, T_{stg}$	-65 to +200	$^\circ\text{C}$

### NOTE:

- Derate linearly 4.6 mW/ $^\circ\text{C}$  for type 2N3019 and 2N3019S; 2.3 mW/ $^\circ\text{C}$  for type 2N3057A; 2.85 mW/ $^\circ\text{C}$  for type 2N3700; 6.6 mW/ $^\circ\text{C}$  for type 2N3700UB for  $T_A \geq +25^\circ\text{C}$
- Derate linearly 28.6 mW/ $^\circ\text{C}$  for type 2N3019 and 2N3019S; 10.3 mW/ $^\circ\text{C}$  for types 2N3057A, 2N3700 & 2N3700UB for  $T_C \geq +25^\circ\text{C}$ .

### ELECTRICAL CHARACTERISTICS ( $T_A = +25^\circ\text{C}$ , unless otherwise noted)

Parameters / Test Conditions	Symbol	Min.	Max.	Unit
<b>OFF CHARACTERISTICS</b>				
Collector-Emitter Breakdown Current $I_C = 30\text{mAdc}$	$V_{(BR)CEO}$	80		Vdc
Collector-Emitter Cutoff Current $V_{CE} = 90\text{Vdc}$	$I_{CES}$		10	$\eta\text{Adc}$
Collector-Base Cutoff Current $V_{CB} = 140\text{V}$	$I_{CBO}$		10	$\mu\text{Adc}$
Emitter-Base Cutoff Current $V_{EB} = 7.0\text{Vdc}$ $V_{EB} = 5.0\text{Vdc}$	$I_{EBO}$		10	$\mu\text{Adc}$ $\eta\text{Adc}$

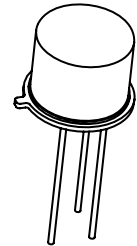

**TO-39 (TO-205AD)**  
2N3019, 2N3019S

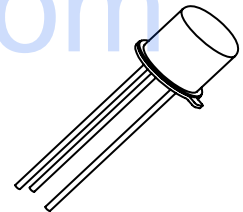

**TO-18 (TO-206AA)**  
2N3700

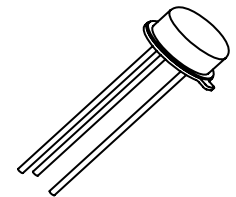

**TO-46 (TO-206AB)**  
2N3057A

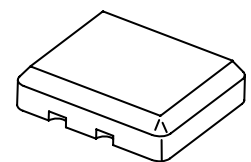

**3 PIN SURFACE MOUNT**  
2N3700UB

## ELECTRICAL CHARACTERISTICS ( $T_A = +25^\circ\text{C}$ , unless otherwise noted) (CONT.)

Parameters / Test Conditions	Symbol	Min.	Max.	Unit
<b>ON CHARACTERISTICS</b>				
Forward-Current Transfer Ratio $I_C = 150\text{mA}$ , $V_{CE} = 10\text{Vdc}$	$h_{FE}$	100	300	
$I_C = 0.1\text{mA}$ , $V_{CE} = 10\text{Vdc}$		50	300	
$I_C = 10\text{mA}$ , $V_{CE} = 10\text{Vdc}$		90		
$I_C = 500\text{mA}$ , $V_{CE} = 10\text{Vdc}$		50	300	
$I_C = 1.0\text{A}$ , $V_{CE} = 10\text{Vdc}$		15		
Collector-Emitter Saturation Voltage $I_C = 150\text{mA}$ , $I_B = 15\text{mA}$	$V_{CE(sat)}$		0.2	Vdc
$I_C = 500\text{mA}$ , $I_B = 50\text{mA}$			0.5	
Base-Emitter Saturation Voltage $I_C = 150\text{mA}$ , $I_B = 15\text{mA}$	$V_{BE(sat)}$		1.1	Vdc

## DYNAMIC CHARACTERISTICS

Parameters / Test Conditions	Symbol	Min.	Max.	Unit
Small-Signal Short-Circuit Forward Current Transfer Ratio $I_C = 1.0\text{mA}$ , $V_{CE} = 5.0\text{Vdc}$ , $f = 1.0\text{kHz}$	$h_{fe}$	80	400	
Magnitude of Small-Signal Short-Circuit Forward Current Transfer Ratio $I_C = 50\text{mA}$ , $V_{CE} = 10\text{Vdc}$ , $f = 20\text{MHz}$	$ h_{fe} $	5.0	20	
Output Capacitance $V_{CB} = 10\text{Vdc}$ , $I_E = 0$ , $100\text{kHz} \leq f \leq 1.0\text{MHz}$	$C_{obo}$		12	pF
Input Capacitance $V_{EB} = 0.5\text{Vdc}$ , $I_C = 0$ , $100\text{kHz} \leq f \leq 1.0\text{MHz}$	$C_{ibo}$		60	pF

## SAFE OPERATION AREA

<b>DC Tests</b>	
$T_C = 25^\circ\text{C}$ , 1cycle, $t = 10\text{ms}$	
<b>Test 1</b>	$V_{CE} = 10\text{Vdc}$
2N3019, 2N3019S	$I_C = 500\text{mA}$
2N3057A, 2N3700, 2N3700UB	$I_C = 180\text{mA}$
<b>Test 2</b>	$V_{CE} = 40\text{Vdc}$
2N3019, 2N3019S	$I_C = 125\text{mA}$
2N3057A, 2N3700, 2N3700UB	$I_C = 45\text{mA}$
<b>Test 3</b>	$V_{CE} = 80\text{Vdc}$
2N3019, 2N3019S	$I_C = 60\text{mA}$
2N3057A, 2N3700, 2N3700UB	$I_C = 22.5\text{mA}$

(1) Pulse Test: Pulse Width =  $300\mu\text{s}$ , Duty Cycle  $\leq 2.0\%$

## PACKAGE DIMENSIONS

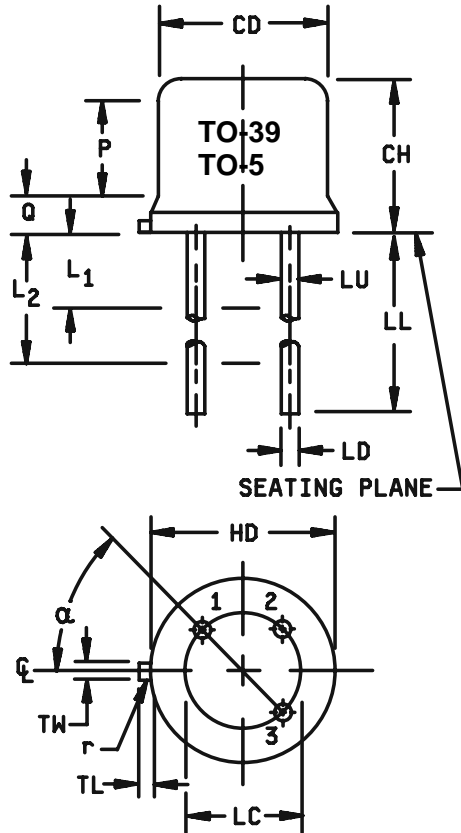

Symbol	Dimensions				Notes
	Inches		Millimeters		
	Min	Max	Min	Max	
CD	.305	.335	7.75	8.51	
CH	.240	.260	6.10	6.60	
HD	.335	.370	8.51	9.40	
LC	.200 TP		5.08 TP		6
LD	.016	.021	0.41	0.53	7, 8
LL	.500	.750	12.70	19.05	7, 8, 12
LU	.016	.019	0.41	0.48	7, 8
L <sub>1</sub>		.050		1.27	7, 8
L <sub>2</sub>	.250		6.35		7, 8
Q		.050		1.27	5
TL	.029	.045	0.74	1.14	4
TW	.028	.034	0.71	0.86	3
r		.010		0.25	10
α	45° TP		45° TP		6
P	.100		2.54		

### NOTES:

1. Dimension are in inches.
2. Millimeters are given for general information only.
3. Beyond r (radius) maximum, TW shall be held for a minimum length of .011 (0.28 mm).
4. Dimension TL measured from maximum HD.
5. Body contour optional within zone defined by HD, CD, and Q.
6. Leads at gauge plane .054 +.001 -.000 inch (1.37 +0.03 -0.00 mm) below seating plane shall be within .007 inch (0.18 mm) radius of true position (TP) at maximum material condition (MMC) relative to tab at MMC. The device may be measured by direct methods.
7. Dimension LU applies between L<sub>1</sub> and L<sub>2</sub>. Dimension LD applies between L<sub>2</sub> and minimum. Diameter is uncontrolled in L<sub>1</sub> and beyond LL minimum.
8. All three leads.
9. The collector shall be internally connected to the case.
10. Dimension r (radius) applies to both inside corners of tab.
11. In accordance with ASME Y14.5M, diameters are equivalent to φx symbology.
12. For "S" suffix devices, dimension LL is 0.500 (12.70 mm) minimum, 0.750 (19.05 mm) maximum.
13. "S" suffix devices, dimension LL is 0.50 (12.70 mm) minimum, 0.75 (19.05 mm) maximum.
14. "L" suffix devices, dimension LL is 1.500 (38.10 mm) minimum, 1.750 (44.45 mm) maximum.
15. Lead 1 = emitter, lead 2 = base, lead 3 = collector.

**FIGURE 1.** Physical dimensions for device types 2N3019 (TO-5) and 2N3019S (TO-39).

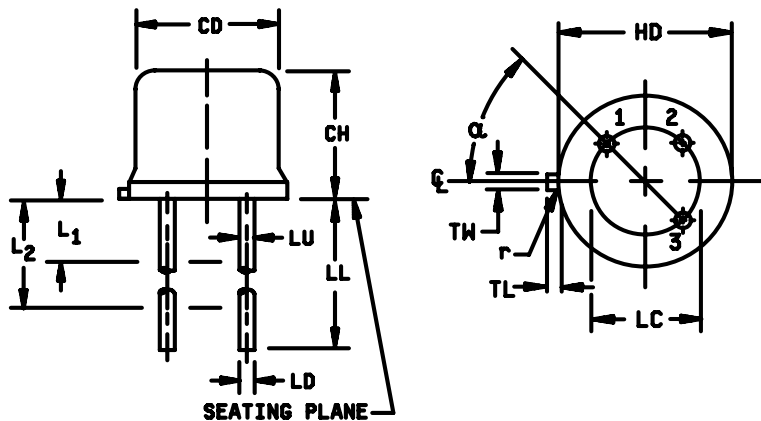

Symbol	Dimensions				Note
	Inches		Millimeters		
	Min	Max	Min	Max	
CD	.178	.195	4.52	4.95	
CH	.065	.085	1.65	2.16	
HD	.209	.230	5.31	5.84	
LC	.100 TP		2.54 TP		6
LD	.016	.021	0.41	0.53	7
LL	.500	1.750	12.70	44.45	7
LU	.016	.019	0.41	0.48	7
L1		.050		1.27	7
L2	.250		6.35		7
TL	.028	.048	0.71	1.22	3
TW	.036	.046	0.91	1.17	2
r		.007		0.18	10, 11
$\alpha$	45° TP		45° TP		6

**NOTES:**

1. Dimension are in inches.
2. Millimeters are given for general information only.
3. Beyond r (radius) maximum, TW shall be held for a minimum length of .011 inch (0.28 mm).
4. Dimension TL measured from maximum HD.
5. Leads at gauge plane .054 +.001 -.000 inch (1.37 +0.03 -0.00 mm) below seating plane shall be within .007 inch (0.18 mm) radius of true position (TP) at maximum material condition (MMC) relative to tab at MMC. The device may be measured by direct methods.
6. Dimension LU applies between L<sub>1</sub> and L<sub>2</sub>. Dimension LD applies between L<sub>2</sub> and LL minimum. Diameter is uncontrolled in L<sub>1</sub> and beyond LL minimum.
7. All three leads.
8. The collector shall be internally connected to the case.
9. Dimension r (radius) applies to both inside corners of tab.
10. In accordance with ASME Y14.5M, diameters are equivalent to  $\phi$ x symbology.
11. Lead 1 = emitter, lead 2 = base, lead 3 = collector.

**FIGURE 2.** Physical dimensions for 2N3057A (TO-46).

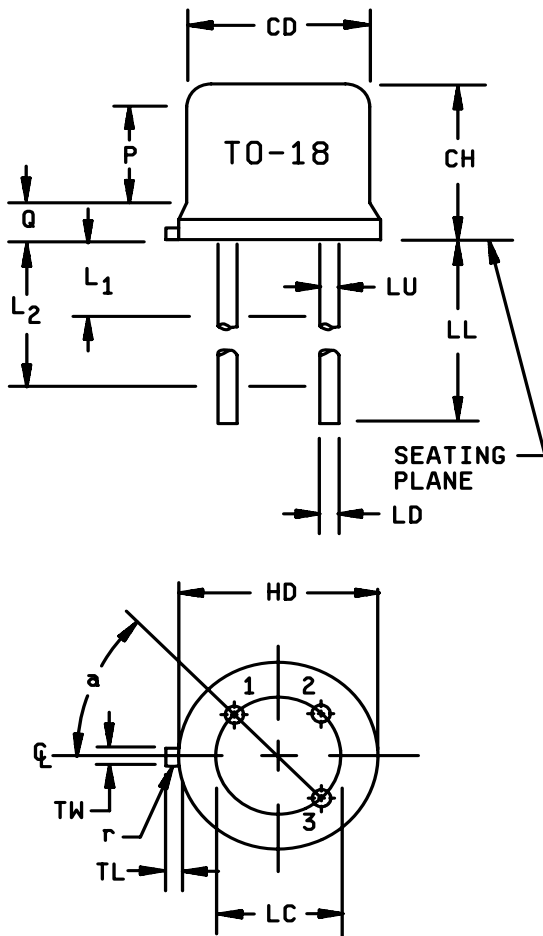

Symbol	Dimensions				Note
	Inches		Millimeters		
	Min	Max	Min	Max	
CD	.178	.195	4.52	4.95	
CH	.170	.210	4.32	5.33	
HD	.209	.230	5.31	5.84	
LC	.100 TP		2.54 TP		6
LD	.016	.021	0.41	0.53	7,8
LL	.500	.750	12.70	19.05	7,8
LU	.016	.019	0.41	0.48	7,8
L1		.050		1.27	7,8
L2	.250		6.35		7,8
P	.100		2.54		
Q		.030		0.76	5
TL	.028	.048	0.71	1.22	3,4
TW	.036	.046	0.91	1.17	3
r		.010		0.25	10
$\alpha$	45° TP		45° TP		6
1, 2, 9, 11, 12					

### NOTES:

1. Dimension are in inches.
2. Millimeters are given for general information only.
3. Beyond r (radius) maximum, TH shall be held for a minimum length of .011 inch (0.28 mm).
4. Dimension TL measured from maximum HD.
5. Body contour optional within zone defined by HD, CD, and Q.
6. Leads at gauge plane .054 +.001 -.000 inch (1.37 +0.03 -.000 mm) below seating plane shall be within .007 inch (0.18 mm) radius of true position (TP) at maximum material condition (MMC) relative to tab at MMC. The device may be measured by direct methods or by the gauge and gauging procedure shown in figure 2.
7. Dimension LU applies between L<sub>1</sub> and L<sub>2</sub>. Dimension LD applies between L<sub>2</sub> and LL minimum. Diameter is uncontrolled in L<sub>1</sub> and beyond LL minimum.
8. All three leads.
9. The collector shall be internally connected to the case.
10. Dimension r (radius) applies to both inside corners of tab.
11. In accordance with ASME Y14.5M, diameters are equivalent to  $\phi$ x symbology.
12. Lead 1 = emitter, lead 2 = base, lead 3 = collector.

**FIGURE 3. Physical dimensions for type 2N3700 (TO-18).**

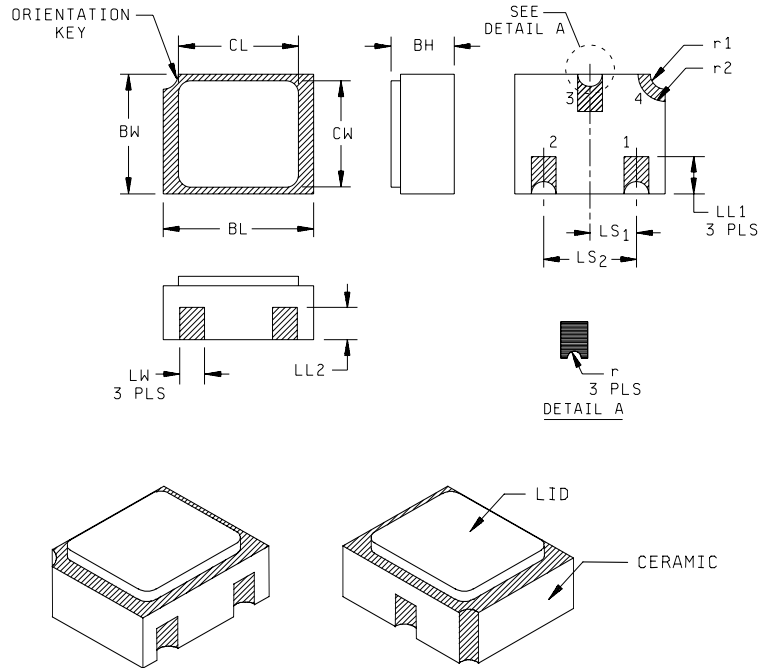

Symbol	Dimensions				Note	Symbol	Dimensions				Note
	Inches		Millimeters				Inches		Millimeters		
	Min	Max	Min	Max			Min	Max	Min	Max	
BH	.046	.056	1.17	1.42		LS <sub>1</sub>	.035	.039	0.89	0.99	
BL	.115	.128	2.92	3.25		LS <sub>2</sub>	.071	.079	1.80	2.01	
BW	.085	.108	2.16	2.74		LW	.016	.024	0.41	0.61	
CL		.128		3.25		r		.008		0.20	
CW		.108		2.74		r <sub>1</sub>		.012		0.31	
LL <sub>1</sub>	.022	.038	0.56	0.96		r <sub>2</sub>		.022		0.56	
LL <sub>2</sub>	.017	.035	0.43	0.89							

**NOTES:**

1. Dimensions are in inches.
2. Millimeters are given for general information only.
3. Hatched areas on package denote metallized areas.
4. Pad 1 = Base, Pad 2 = Emitter, Pad 3 = Collector, Pad 4 = Shielding connected to the lid.
5. In accordance with ASME Y14.5M, diameters are equivalent to  $\phi x$  symbology.

**FIGURE 4.** Physical dimensions, surface mount (2N3700UB).